

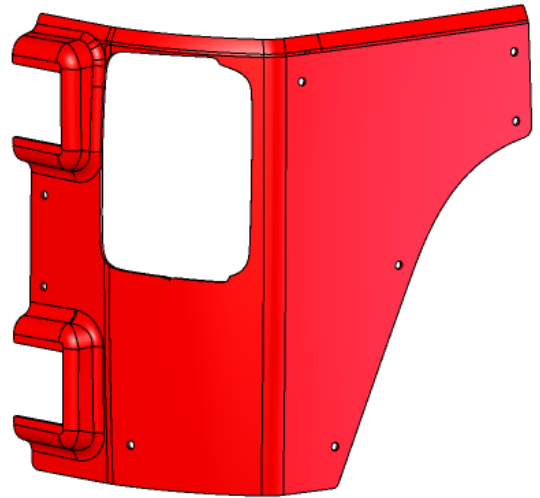

JK CORNER GUARD KIT

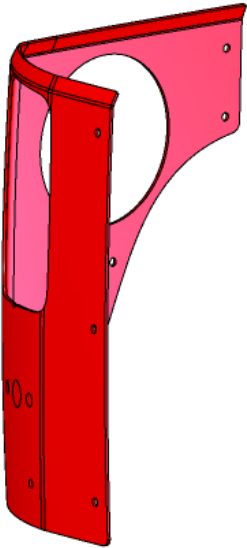

Installation Guide



PLEASE READ BEFORE YOU START

TO GUARANTEE A QUALITY INSTALLATION, WE RECOMMEND READING THESE INSTRUCTIONS THOROUGHLY BEFORE BEGINNING ANY WORK. THESE INSTRUCTIONS ASSUME A CERTAIN AMOUNT OF MECHANICAL ABILITY AND ARE NOT WRITTEN OR INTENDED FOR SOMEONE NOT FAMILIAR WITH AUTO BODY REPAIR.

Included Parts	QTY	Required Tools
Corner guard, right	1	Center Punch
Corner guard, left	1	Common Hand Tools
Riv-nut	17	Touch Up Paint
Screw	17	File or De-Burring Tool
Riv-nut installation tool	1	Wax pencil for marking holes
		Drill Motor
		Drill Bits



INSTALLATION

A. IDENTIFY 2 DOOR VS. 4 DOOR

1. Because the 2 door and 4 door guards look nearly identical it is important to make sure you have the correct corner guards for your vehicle type. 2 door and 4 door corner guards are different, and are not interchangeable. Please take the time to double check the part numbers on your packaging.

2 DOOR PART #: 10303012AA

4 DOOR PART #: 10303014AA

2. If your parts do not have a very close fit (less than 1-2 mm gaps) please call our technical support line at 406.251.2100.

B. REMOVAL OF TAIL LAMPS

1. Remove the two inboard Phillips screws and remove tail lamp by carefully sliding the lamp toward the tail gate.
2. Disconnect the tail lamp wiring harness and set the lamps aside

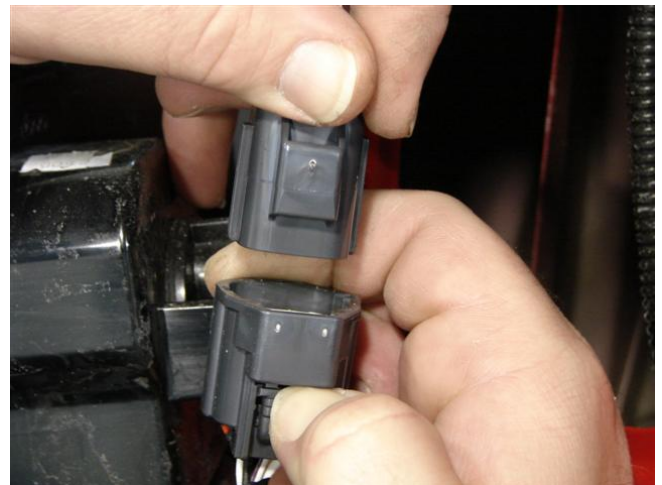

C. REMOVAL OF TAILGATE HINGE COVERS

1. Using a flat screwdriver, carefully lift each corner of the hinge cover
2. Spread hinge cover and slide outward as shown. Remove and discard covers



D. REMOVAL OF LICENSE PLATE BRACKET

1. Remove License plate
2. Remove the 2 screws behind the license plate
3. Remove the 2 screws at the bottom of the bracket behind rear bumper
4. Disconnect wiring harness and set the bracket aside





E. INSTALL CORNER GUARDS

1. Hold corner guard in place on vehicle
2. While holding the guard in place, have a helper re-install the tail lamp. Take care to ensure the tail lamps mount to the vehicle into their original location. Double check the tail lamp location and temporarily re-install the 2 mounting screws.
3. **Alignment of the corner guard is very important.** Check all the gaps and adjust the guard as necessary to achieve uniform margins. Use painter's tape to hold the guard in place on the vehicle. Step back a few feet and double check the margins paying close attention to the alignment at the top, bottom, sides, along the tailgate, flare, etc.





AMERICAN EXPEDITION
VEHICLES

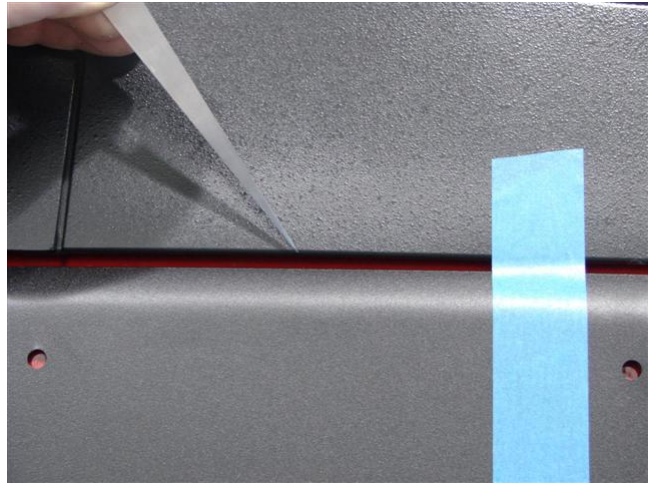

4. Mark the holes and center punch.





5. Remove the tail lamp
6. Remove the corner guard and set aside taking care not to scratch the surface
7. Set a drill stop 1/2 inch deep and drill 1/8 inch pilot holes
8. Finish drilling with a 25/64 inch (10mm) drill bit with 1/2 inch depth stop
9. De-burr the holes with a file or de-burring tool
10. Apply rust preventative primer, or touch up paint (such as Mopar Part #: 82300508) to the drilled holes

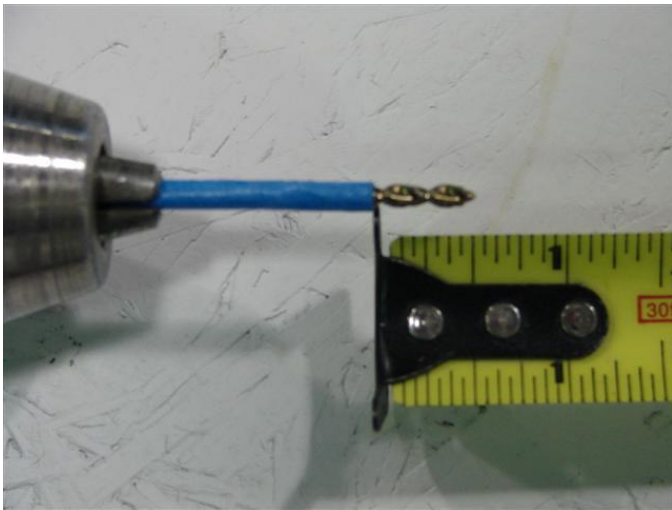

11. Assemble riv-nut installation tool with the tapered end of the sleeve pointing toward the end of the bolt
12. Screw riv-nut onto the tool
13. Insert the tool with nut into drilled hole, making sure it seats fully onto body

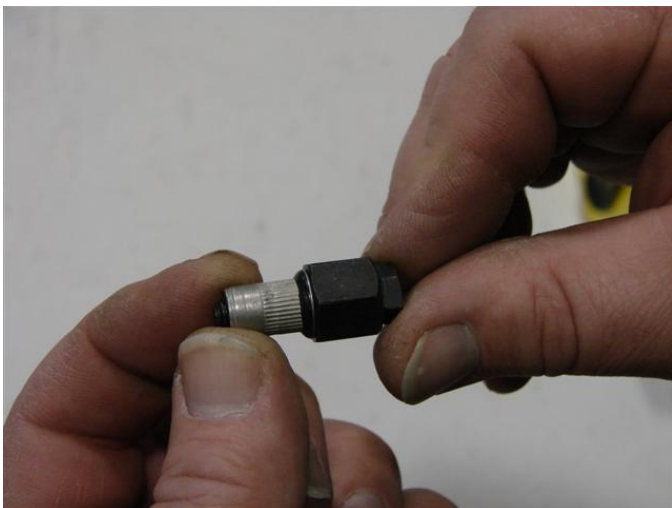



A M E R I C A N E X P E D I T I O N
V E H I C L E S

14. Hold the nut portion of the tool with an open end wrench, and slowly turn the bolt portion of the tool with a ratchet, applying inward pressure
15. Torque the bolt until the riv-nut seats fully. A small drop of oil between the tool and riv-nut helps keep the tool spin smoothly





AMERICAN EXPEDITION
VEHICLES

1. Install corner guards on vehicle
2. Re-install tail lamps and connect wiring
3. Re-install license plate bracket and wiring





A M E R I C A N E X P E D I T I O N
V E H I C L E S

COMMENTS OR QUESTIONS?

American Expedition Vehicles

Phone: 406.251.2100

Email: tech@aev-conversions.com

Website: <http://www.aev-conversions.com>