



FRONT RUNNER

**SLIMLINE II TRAY
UNIVERSAL ASSEMBLY
INSTRUCTIONS**

ENG

RRSTUNI



INSTALL TIME: 30 mins



NOTE: The Slimline II Tray size that you are assembling may differ from the one shown in this instruction manual.

IMPORTANT WARNING!

IT IS CRITICAL THAT ALL FRONT RUNNER PRODUCTS BE PROPERLY AND SECURELY ASSEMBLED AND ATTACHED TO YOUR VEHICLE. IMPROPER ATTACHMENT COULD RESULT IN AN AUTOMOBILE ACCIDENT, AND COULD CAUSE SERIOUS BODILY INJURY OR DEATH TO YOU OR TO OTHERS. YOU ARE RESPONSIBLE FOR ASSEMBLING AND SECURING ALL FRONT RUNNER PRODUCTS TO YOUR VEHICLE, CHECKING THE ATTACHMENTS PRIOR TO USE, AND PERIODICALLY INSPECTING THE PRODUCTS FOR ADJUSTMENT, WEAR, AND DAMAGE. THEREFORE, YOU MUST READ AND UNDERSTAND ALL OF THE INSTRUCTIONS AND CAUTIONS SUPPLIED WITH YOUR FRONT RUNNER PRODUCT PRIOR TO INSTALLATION OR USE. IF YOU DO NOT UNDERSTAND ALL OF THE INSTRUCTIONS AND CAUTIONS, OR IF YOU HAVE NO MECHANICAL EXPERIENCE AND ARE NOT THOROUGHLY FAMILIAR WITH THE INSTALLATION PROCEDURES, YOU SHOULD HAVE THE PRODUCT INSTALLED BY A PROFESSIONAL INSTALLER OR OTHER QUALIFIED PERSONNEL.

1 GET ORGANIZED...

Depending on which size Slimline II Tray you ordered, quantities may vary from those pictured. Here is what you are looking at:

Item #	Quantity	Description
1	8 - 32	M8 NYLOC NUT
2	0 or 4	M8 x 45 BUTTON HEAD BOLT
3	0 or 2	THICK JOINER PIECE
4	0 or 2	THIN JOINER PIECE
5	2 or 4	SIDE PROFILE
6	4	CORNER
7	2	COMBINED SLAT
8	8 - 28	M8 x 25 BUTTON HEAD BOLT
9	2 - 12	STANDARD SLAT
10	4	M6 x 12 BUTTON HEAD BOLT

- You will need:**
- a Clean dry work area
 - a 4mm Hex Key
 - a 5mm Hex Key

HINT: Assemble your Slimline II Rack on a dust cover or old blanket to prevent it from being scratched during assembly.

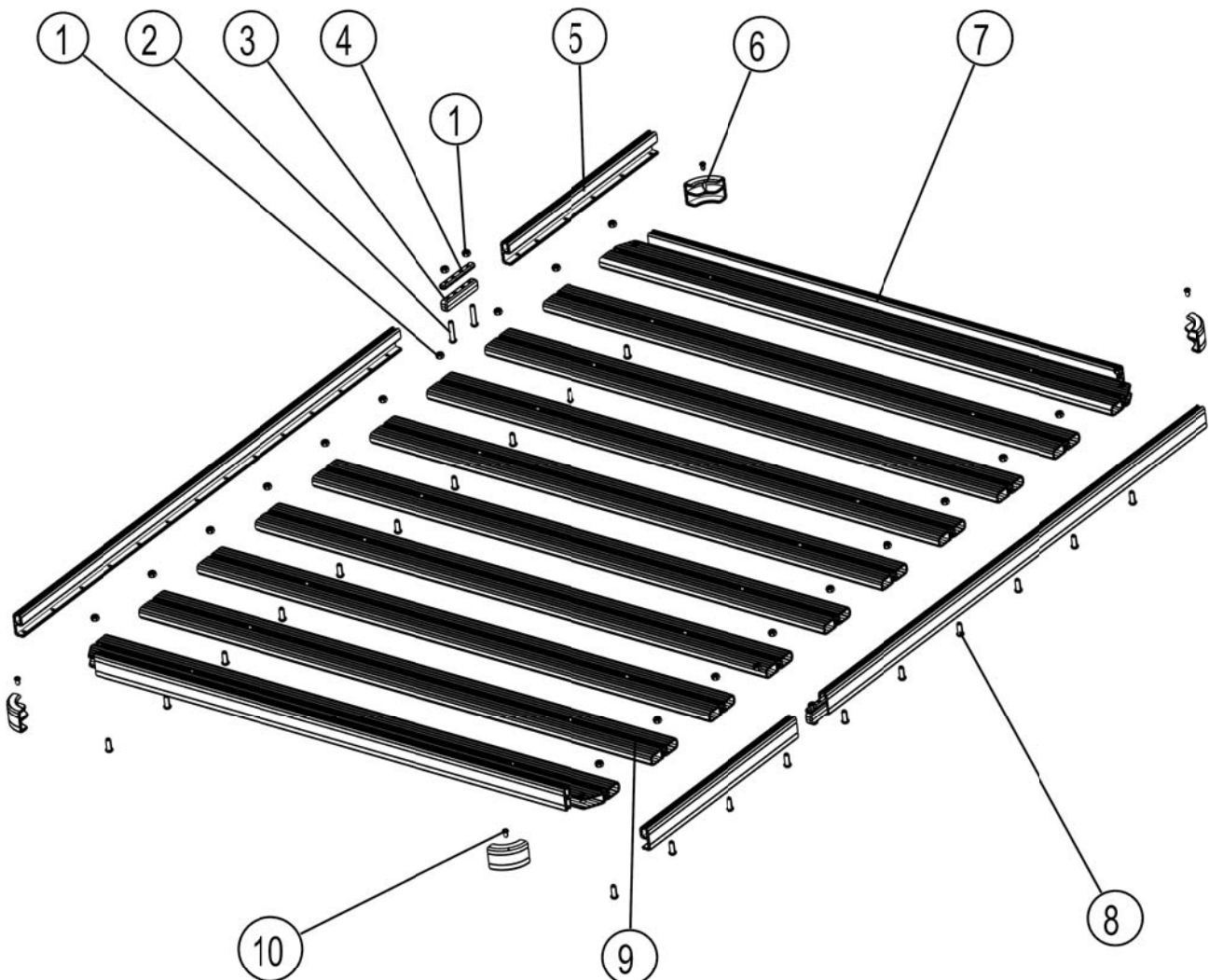

(A) Familiarize yourself with the parts and then step away from the work area and read through these instructions from beginning to end. Grab a cup of coffee and take a moment. A little prep now may save you a lot of time later.

2 ASSEMBLE SIDE PROFILE



NOTE: Skip this step if your Slimline II Tray is 1560mm or shorter. You only have two Side Profiles and assembly is not needed.

If you have received four lengths of Side Profile (Item 4), you will need to join the pieces together using the Joiners (Items 2 & 3) to form only two lengths by following the easy steps below.

With the exception of a 2772mm long Slimline II Tray, the joints in the Side Profiles will be diagonally opposite each other once the Tray is assembled.

Item #	Quantity	Name
1	4	M8 NYLOC NUT
2	2	THICK JOINER
3	2	THIN JOINER
4	4	SIDE PROFILE
5	4	M8 x 45 BUTTON HEAD BOLT

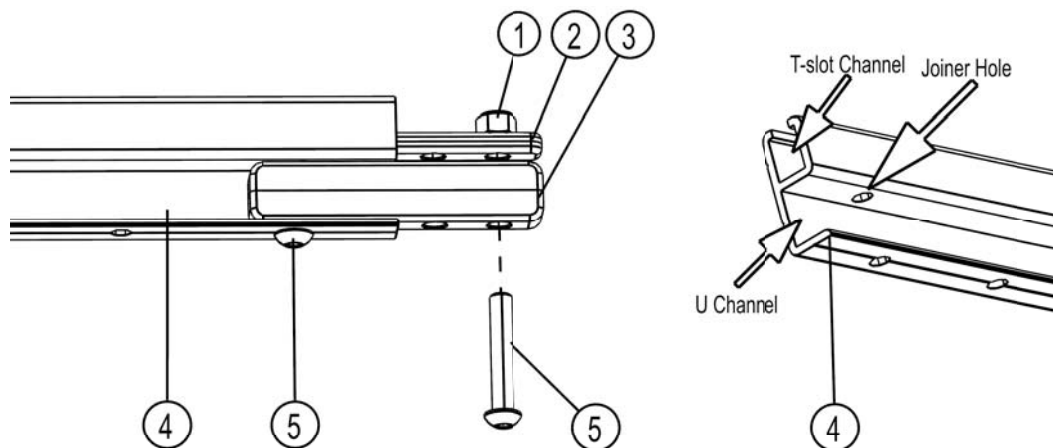

- (A) The Side Profiles are packed in pairs. Take one profile from each pair, one short and one long (Except for a 2772mm long Slimline II Rack where the Side Profiles will be the same length. Even though both pairs are the same length it is still important that you take one Side Profile from each pair).

If you look at the two Side Profiles you will see that at one end of each profile there is a hole that goes through the top and bottom of the "U" Channel of the Side Profile (Refer to Image above.) These are the Joiner Holes that you will be using.

- (B) Insert a Thick Joiner (Item 3) into the "U" Channel of one of the Side Profiles lining up the first hole with the Joiner Hole, still leaving two of the holes over the edge of the Side Profile - Refer to Image above.

Now grab a Thin Joiner (Item 2) and Nyloc Nut (Item 1). Slide the Thin Joiner into the "T-slot" Channel, followed by the Nyloc Nut. The Nyloc Nut should sit on top of the Thin Joiner with the "Dome" of the Nyloc Nut facing up. Line up the outer hole of the Thin Joiner and Nyloc Nut with the Joiner Hole and hand fasten it all together using a M8 x 45 Button Head Bolt (Item 5) and a 5mm Allen Wrench.

Slide the matching Side Profile over the two Joiner pieces, remembering to insert a Nyloc Nut, and fasten once again using a M8 x 45 Button Head Bolt. Repeat the above steps for the other side.

3 ASSEMBLE OUTER FRAME

- (A) Look at the Combined Slat and ensure that there is a Nyloc Nut inserted into each machined end pocket. If the Nyloc Nut has fallen out during shipping, insert it back into the pocket as seen in the illustration below.

The "Dome" of the Nyloc Nut should be facing up. It is a light press fit, so you may need to give the Nyloc Nut a gently tap with a hammer if you are not able to press it in with your thumb.

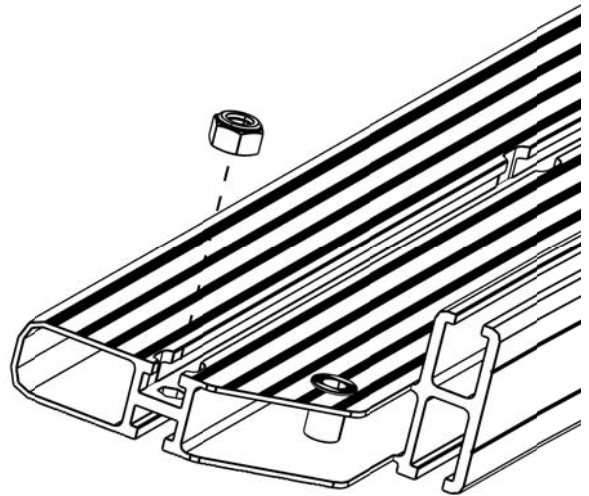

- (B) Turn the Combined Slat (Item 1) upside down as shown in the image below. Slide the two Side Profiles (Item 3) over the Combined Slat and align the holes. The end hole of the Side Profile should align to the hole in the Combined Slat.

Grab a M8 x 25 Button Head Bolt (Item 2) and loosely tighten using a 5mm Hex Key.

Item #	Quantity	Description
1	2	COMBINED SLAT
2	2	M8 x 25 BUTTON HEAD BOLT
3	2	SIDE PROFILE

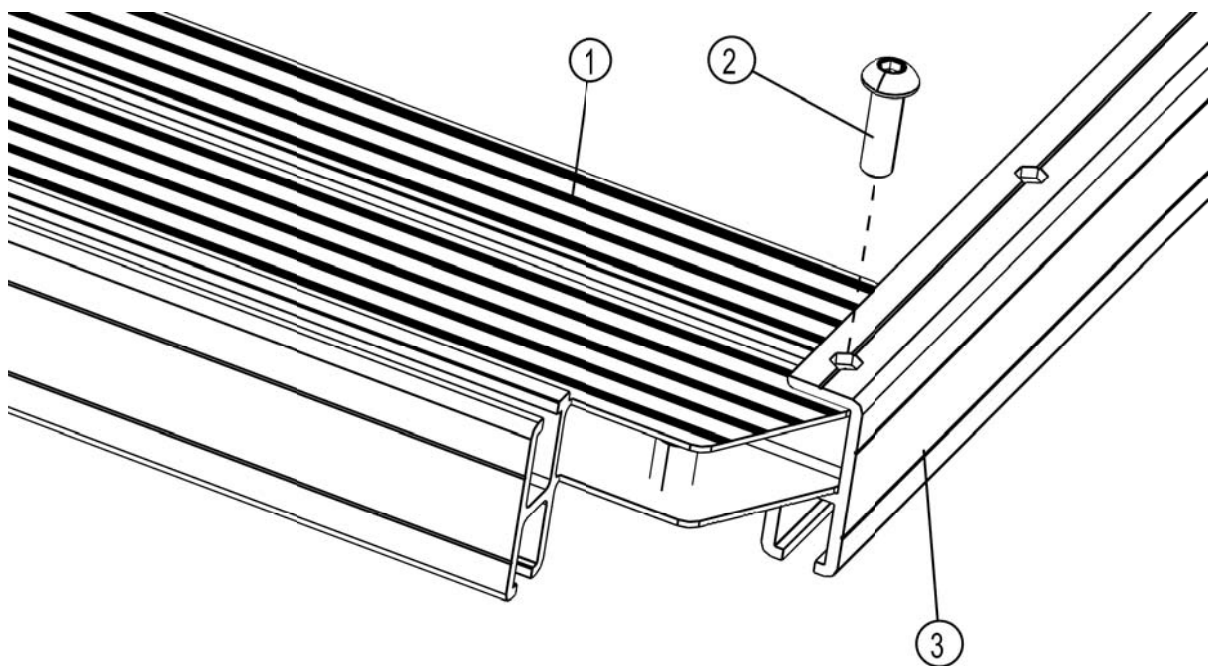

4 ASSEMBLE SLATS

- (A) Take a Standard Slat (Item 9 from Page 2) and as with the Combined Slat ensure that the Nyloc Nut is in the machine end pocket. Slide the Standard Slat between the two Side Profiles with the Nyloc Nut side facing down. Position the slat so that the hole in the slat lines up with the third hole in the Side Profile.

Grab a M8 x 25 Button Head Bolt and loosely fasten the Standard Slat to the Side Profile using a 5mm Hex Key. Repeat the process for the remaining Standard Slats making sure that there is an open hole in the Side Profile between each slat. Refer to illustration below.

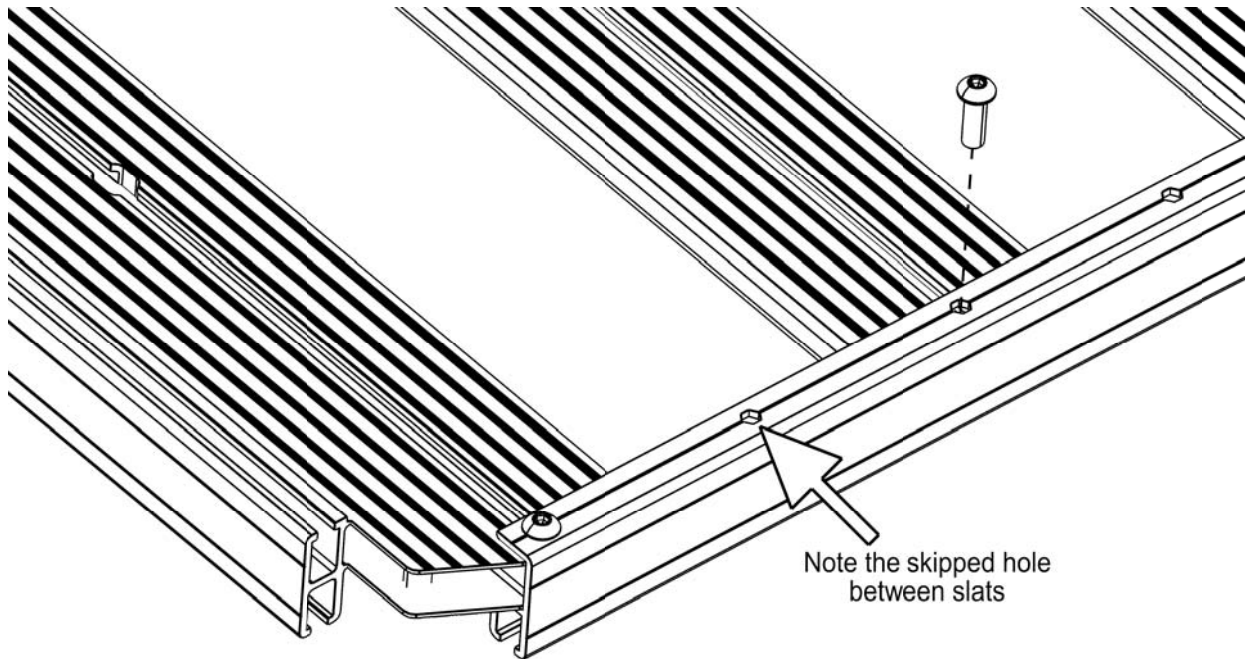

5 ASSEMBLE SECOND COMBINED SLAT

- (A) Review Step 3A - Then slide the Combined Slat into the two Side Profiles and fasten as per Step 3B.

6 FASTEN ALL BOLTS

- (A) Using your 5mm Hex Key, tighten all the Button Head bolts - (The recommended torque setting for the M8 Button Head Bolts is 20 Nm or 15 ftlb)

7 ASSEMBLE THE CORNERS

NOTE: If you are planning on fitting accessories to your Slimline II Rack at the same time as fitting the Slimline II Rack to your vehicle, you may wish to leave the Corners off for now.



Some Slimline II Rack accessories require you to remove the corners for installation. Read the accessory installation guide to see whether this is the case.

Hint: Even if the Corner is fitted, you are still able to slide a M8 Nyloc Nut into the "T-slot" Channel through the side of the Corner.

(A) Now is the time to fit the Corners and complete your Slimline II Rack assembly! Flip the Tray over so it is right side up.

(B) Push the Corner into position as shown, lining the hole in the Corner up with the Rivnut already inserted in the Combined Slat. Grab a 4mm Hex Key and M6 x 12 Button Head Bolt (Item 10 from Page 2) and fasten the Corner in position.

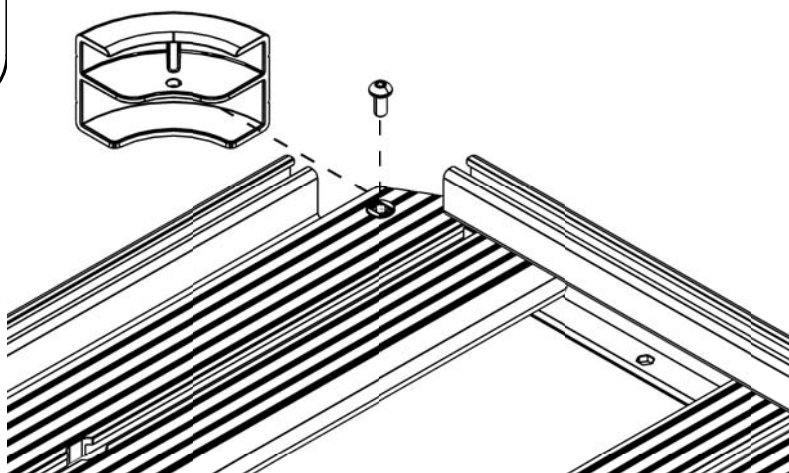

8 GET ORGANIZED TO FIT YOUR WIND DEFLECTOR

Item #	Quantity	Description
1	1	SLIMLINE II TRAY
2	4	M8 HALF NUT
3	2	WIND DEFLECTOR (1 LEFT, 1 RIGHT)
4	4	SCHNORR WASHER
5	4	M8 x 12 BUTTON HEAD BOLT

You will need:

- a 5mm Hex Key
- a Tape Measure

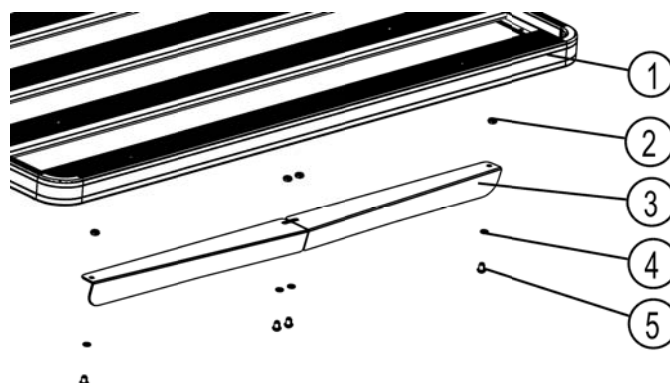

NOTE: Once your Slimline II Roof Rack is fitted, ensure a 15mm clearance is maintained between the Wind Deflector and the vehicles roof otherwise damage to the roof may occur. Bend the Wind Deflector by hand if necessary.

9 FIT WIND DEFLECTOR



NOTE: The Wind Deflector must be fitted to the front Combined Slat.

If you are going to put a Leg or Foot on the Combined Slat (Often Recommended), you will need to slide the M8 Bolts used for attaching these into the Machined Slots before assembling the Wind Deflector.

- (A) Ensure that your Slimline II Tray is upside down. Check by looking at the product sticker. It should be upside down as shown.



- (B) Insert two Button Head Bolts, M8 Half Nuts and Schnorr Washers (Items 2, 4 & 5) into the Combined Slat as illustrated. Slide them to the centre of the Combined Slat making sure that the Schnorr Washers sit above the T-slot Channel.

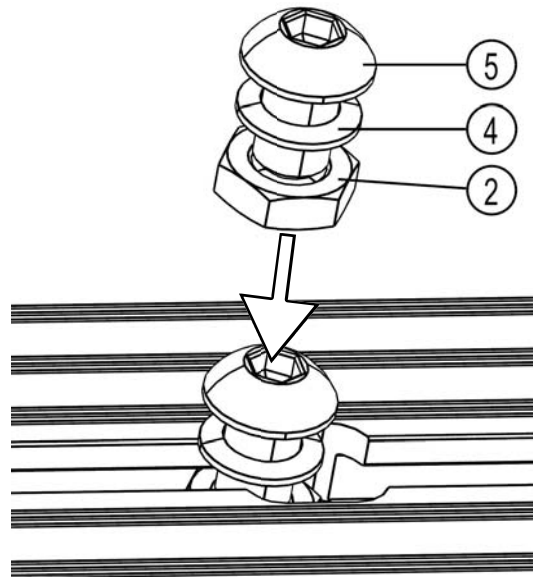
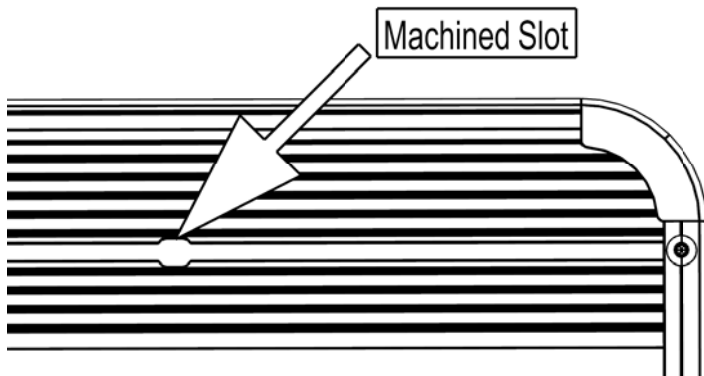

- (C) Place a Rubber Strip (Supplied) underneath each of the Wind Deflectors. Assemble Items 2, 4 & 5 as illustrated on both Wind Deflectors.

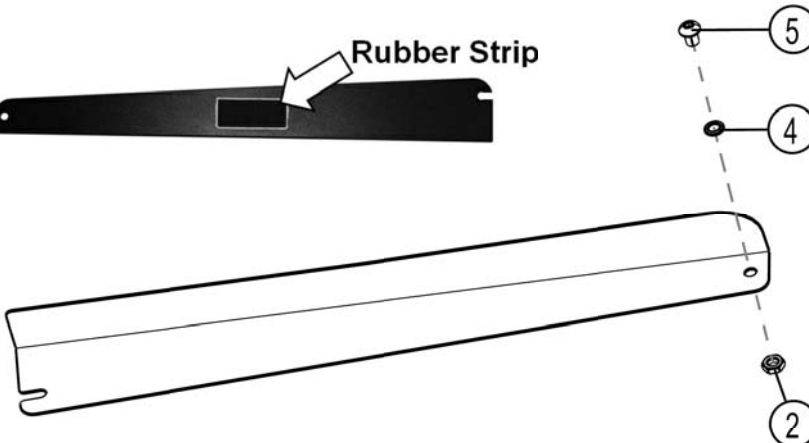

9 FIT WIND DEFLECTOR...CONT.

- (D) Slide the Wind Deflectors - with the Button Head Bolts, Schnorr Washers and Half nuts already attached (Refer to Step 2C) - into the T-slot of the Combined Slat with the nut and bolt assembly going towards the outside of the Slimline II Tray.

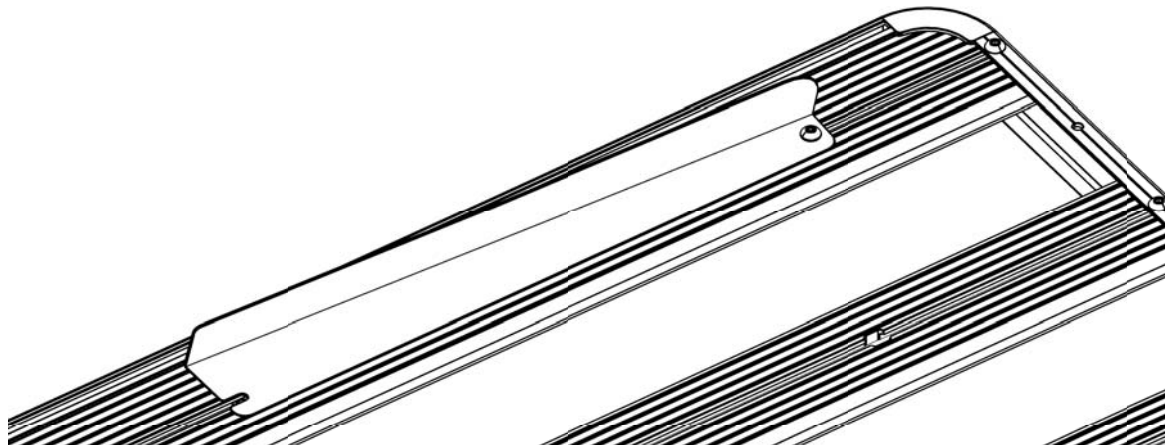

- (E) Slide both Wind Deflectors to the centre of the Combined Slat, guiding the Button Head Bolts and Schnorr Washers into the horse shoes as shown below. The Schnorr Washer must sit above the Wind Deflector.

Using a Tape Measure, centre the Wind Deflectors using the outer edges of the Slimline II Tray and Wind Deflectors as reference.

Once you are happy with the positioning of the Wind Deflectors, fasten the four Button Head Bolts using a 5mm Hex Key.

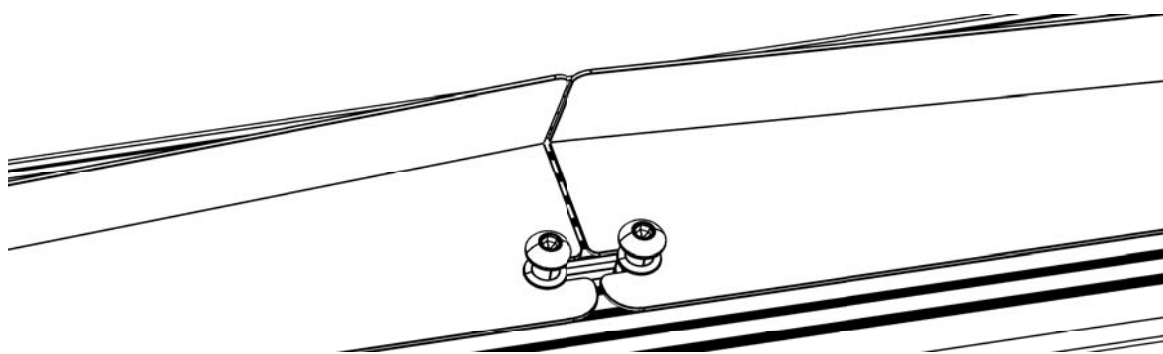

10 CHECK YOUR VEHICLE INSTALLATION GUIDE

- (A) Now that your Slimline II Tray is assembled, get your Rack Kit Installation Guide out and follow the instructions to fit the Slimline II Tray to your specific vehicle.