

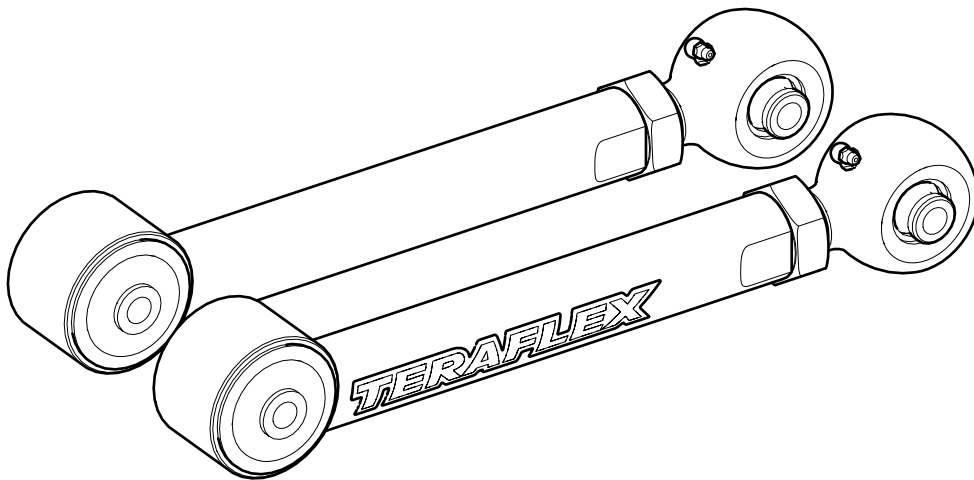

TJ/LJ/XJ/ZJ Lower Control Arms

www.teraflex.com

Kit #1615700



Important Notes:

Prior to beginning this or any installation read these instructions to familiarize yourself with the required steps and

Tools needed:

- This installation guide
- Basic mechanics tool set

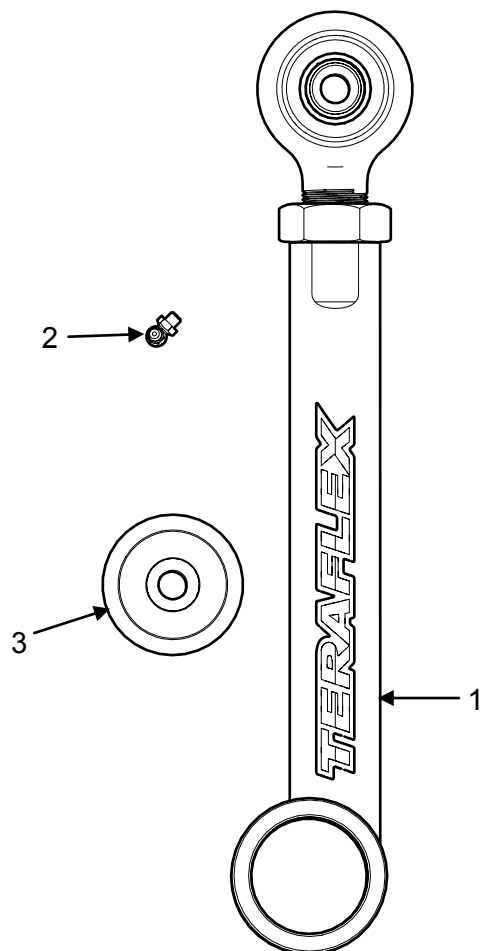

Parts List			
Item Number	Part Number	Description	Quantity
1	645709	TJ Front and Rear Lower FlexArm	2
2	30890	Grease Zerk 1/4"-28 UNF 90 Degree	2
3	4915161	Large Clevite Rubber Bushing	2

FRONT REMOVAL

Raise and support the front of the vehicle. If the vehicle is equipped with ABS, remove the sensor wire from the inboard side of the arm. Remove and install only one arm at a time, then proceed to the next arm.

1

Remove the lower frame side bolt with a 21mm.

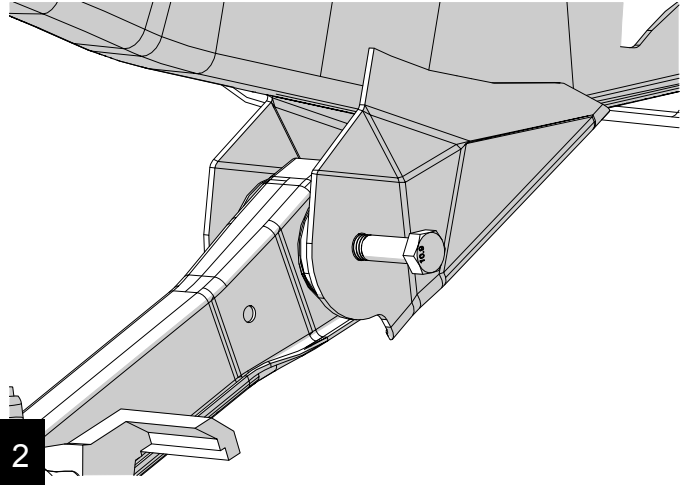

2

Remove the lower axle side cam bolt and nut with a 21mm. Remove the control arm.

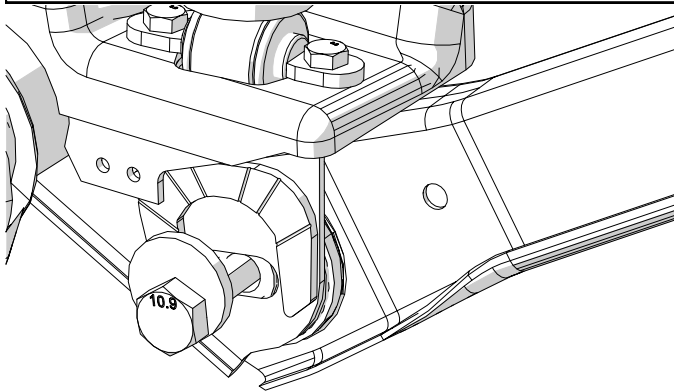

3

FRONT INSTALLATION

Lengthen the arms according to the list below. The given lengths are starting points only, you will need a 4 wheel alignment after installation. The cam bolt will no longer be used for alignment purposes. Tighten the jam nuts with an 1 1/4". Grease the flex-joint now and once per month after.

TJ's, LJ's and ZJ's - 15 3/4"

XJ's Front- 16 1/4"

WJ's Front - 16"

4

Slide the bushing side of the flex arm into the frame side bracket. Install the nut and bolt. Tighten finger tight.

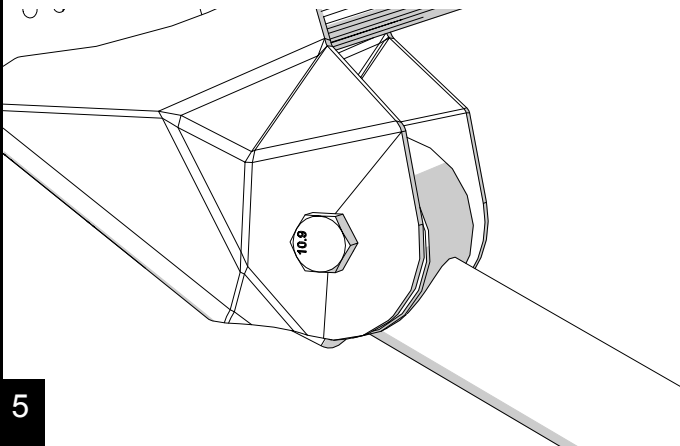

5

Install the flex-joint side into the axle bracket with the cam bolt. Rotate the cam bolt until it has shifted all the way forward. Tighten finger tight. Repeat steps 2-6 for the remaining front lower arm, then lower the vehicle and torque the cam bolts to 85 ft-lbs and frame side bolts to 130 ft-lbs.

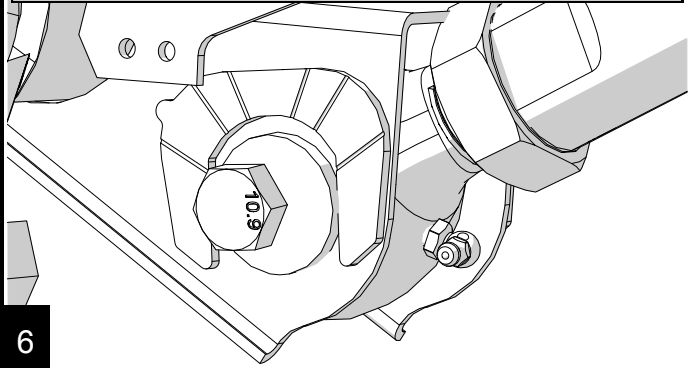

6

REAR REMOVAL

Raise and support the rear of the vehicle. Remove and install only one arm at a time, then proceed to the next arm.

7

Remove the lower axle side nut and bolt.

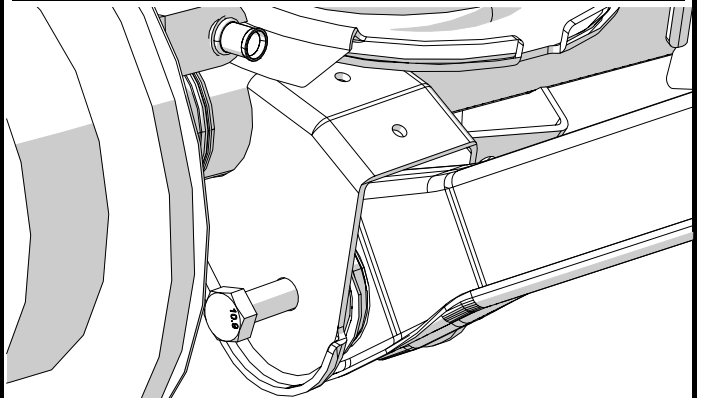

8

Remove the frame side nut and bolt. Remove the arm.

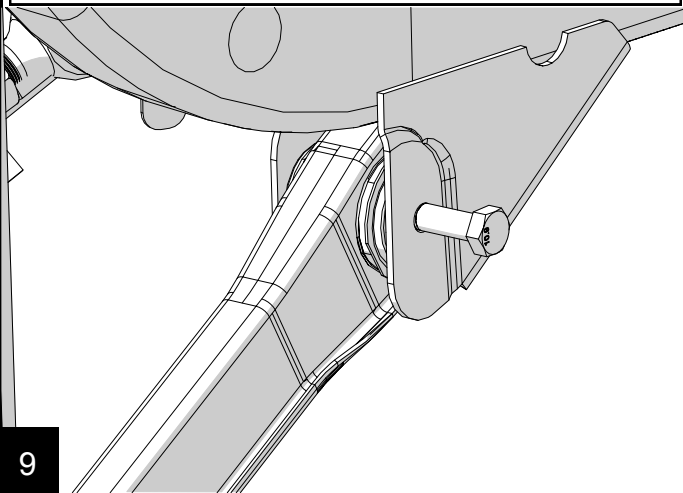

9

REAR INSTALLATION

Lengthen the arms according to the list below. The given lengths are starting points only, you will need a 4 wheel alignment after installation. Tighten the jam nuts with an 1 1/4" after install. Grease the flex-joint now and once per month after.

- TJ's and LJ's - 15 3/4"
- ZJ's Rear - 16 11/16"
- WJ's Rear - 19"

10

Slide the bushing side of the flex arm into the frame side bracket. Install the nut and bolt. Tighten finger tight.

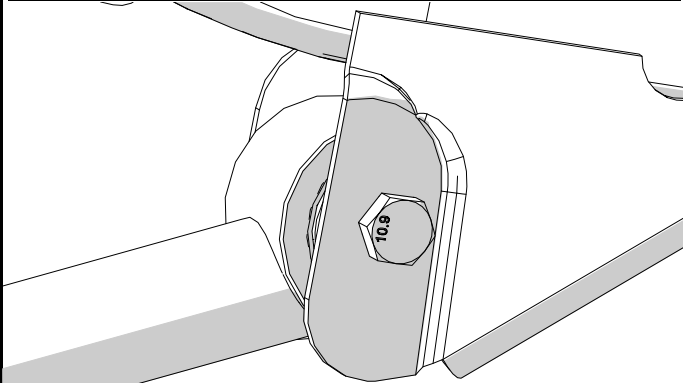

11

Install the flex-joint side of the arm into the axle side bracket. Tighten finger tight. Repeat steps 8-12 for the remaining rear lower arm. Lower the vehicle and torque all bolts to 130 ft-lbs.

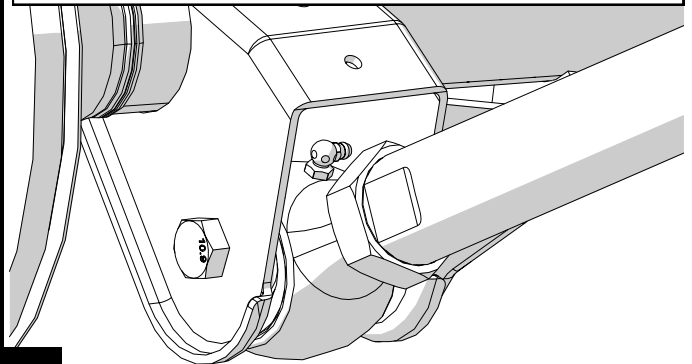

12

PRODUCT INFORMATION

MAINTENANCE INFORMATION:

It is the buyer's responsibility to have all suspension, drivetrain, steering, and other components checked for proper tightness and torque after the first 100 miles and every 3000 miles after that.

NOTICE TO INSTALLER:

The enclosed "Warning to Driver" sticker must be installed in the vehicle in driver's view. This sticker is to act as a constant safety reminder when operating the vehicle. It is your responsibility as the equipment installer to install the provided sticker and to forward the product instructions to the vehicle's owner for review. If a "Warning to Driver" sticker or product installation guide were not included in the kit, FREE replacement stickers and instructions are available by request. It is the installer's duty to ensure a safe and controllable vehicle after the modifications have been performed.

WARNING:

Neither the seller nor the manufacturer will be liable for any loss, damage, or injury directly or indirectly arising from the use of or inability to determine the use of these products. Before using, the user shall determine the suitability of the products for its intended use, and the user shall assume all responsibility and risk in connection therewith.

WARNING TO DRIVER:

This vehicle has been modified to enhance off road performance and has unique handling characteristics. Use in harsh environments can cause extreme stress on the components. Vehicle should be inspected after being off road to make sure that all the components are in working order and safe to travel on the highway. All fasteners should be checked so that they are at the correct torque specifications as the vibration and stresses from off roading may cause critical fasteners to work loose. Extra care should be taken to inspect the critical components, steering, and brake systems. During each oil change components such as arms, tie rod ends, etc should be greased and checked for excessive wear. Any worn components should be replaced. When returning to the pavement always set or restore tire air pressure to the factory recommendation and connect or engage any disabled sway bar mechanisms. Because of the higher center of gravity and larger tires, this vehicle handles and reacts differently than many passenger cars, both on and off road. You must drive it safely! Extreme care should be taken to prevent vehicle rollover or loss of control, which can result in serious injury or death. Avoid sudden sharp turns or abrupt maneuvers. Generally, braking performance and capabilities are decreased when significantly larger/heavier tires are used, especially when used in combination with transfer case low-range reduction kits. Take this into consideration while driving. Do not add, alter or fabricate any factory or aftermarket parts to increase vehicle height over the intended height of the TeraFlex product purchased. Mixing component brand is not recommended. TeraFlex Inc. will not be responsible for any altered product or any improper installation or use of our products. We will be happy to answer any questions concerning the design, function, and correct use of our products. It is ultimately the buyer's responsibility to have all bolts/nuts checked for tightness after the first 100 miles and then every 3000 miles. Wheel alignment, steering system, suspension and drive line systems must be inspected by a qualified professional mechanic at least every 3000 miles.

TERAFLEX PRODUCT WARRANTY:

TeraFlex Inc. warrants TeraFlex Suspension products to the original retail purchaser to be free of defects in material and workmanship for as long as the original purchaser owns the vehicle on which products were originally installed.

Failure to complete regular maintenance (grease every 3000 miles) on TeraFlex FlexArms will void this warranty. All other conditions of the standard TeraFlex product warranty apply.

All TeraLow products are covered by the TeraFlex two (2) year warranty to be free of defects in material and workmanship for two years from date purchased.

TeraFlex axles are covered by a 12-month warranty to be free of defects in materials and workmanship.

This warranty does not cover or include product finish, improperly installed or applied products, improperly maintained products, products or components used for racing or competition or damage due to abuse or neglect, products that fail due to the use of larger tire and wheel combinations.

All returns must be accompanied by an original invoice. It is the customer's responsibility to remove the product from the vehicle. Shipping charges are the responsibility of the customer. TeraFlex Inc. will pay the return freight if the product meets the terms of warranty.

This warranty is for the replacement or repair of defective TeraFlex products only and does not include freight charges, labor charges for removal of or installation of TeraFlex or related products or components, costs incurred due to down time of the vehicle, or lost profits due to vehicle down time.

A returned goods authorization number (RGA#) must accompany any returned products. For more information please contact a TeraFlex customer service representative.

COPYRIGHT

©Copyright 2014. All rights reserved, TeraFlex Inc. Reproduction of this catalog and/or any of its contents without written permission is strictly prohibited.

TeraFlex® is a registered trademark of TeraFlex Inc. All trade names and logos including but not limited to TeraFlex, FlexArms, RockGuard, Monster, and LCG are protected by law and duplication of trade names and/or logos are strictly prohibited.

TeraFlex Inc. reserves the right to update, discontinue, redesign, modify finish, part number or component build parts if deemed necessary without written notice.

TeraFlex Inc., and any associated dealers are not responsible for misprints or typographical errors that may have inadvertently been made within this instruction sheet.

Jeep® and the Jeep® grill are registered trademarks of Fiat Chrysler Automobiles N.V., and have no affiliation with TeraFlex Inc.

TERAFLEX, Inc.
5680 West Dannon Way
West Jordan, Utah 84081
Phone/801.713.3314
Fax/801.713.2313
www.teraflex.com