











# Installation Instructions Supertop® with Tinted Side and Rear Windows

## Vehicle Application

- Jeep Wrangler Unlimited JK  
2007 – Current  
Part Number: 54717

[www.Bestop.com](http://www.Bestop.com) - We're here to help! Visit our web site and click on ["Ask a Question"](#). Click here for more [Jeep Accessories by Bestop](#).

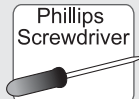
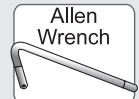
<b>INSTALLATION TIME</b>	<b>SKILL LEVEL</b>
 <b>3 Hours</b>	 <b>3 - Moderately Hard</b>

TOOLS			
 Phillips Screwdriver #2	 Wrench 10mm and 3/8"	 Power Drill #2 Phillips Bit	 Pliers
 Phillips Screwdriver #1	 Allen Wrench 1/8"	 Masking Tape	 Safety Glasses



	<b>CAUTION</b>	Safety glasses should be worn at all times while installing this product.
---	----------------	---

### Installation Tips

Before you begin installing this assembly, read all instructions thoroughly.

#### For a smooth fit:

For ease in installation, the product should be installed at temperatures above 72° F. Below this temperature, the fabric may contract an inch or more, making it difficult to fit to the vehicle. It is normal for fabric to contract and wrinkle when stored in the shipping carton. Within a few days after the installation, the fabric will relax and the wrinkles will disappear.

**! WARNING** This product is designed primarily to enhance the appearance of the vehicle and to shield the occupants from ordinary weather conditions. Do not rely in any way on the components of this product to contain occupants within the vehicle, or to protect against injury or death in the event of an accident. This product will not protect the occupants from falling objects. Never operate the vehicle in excess of manufacturer's specifications.

#### WEAR SEAT BELTS AT ALL TIMES

Read and follow, precisely, all installation instructions provided when installing product. Failure to do so may result in a poor fit and could place occupants of the vehicle in a potentially dangerous situation.

# Supertop® with Tinted Windows – Installation Instructions

Top Fabric	Qty - 1
Quarter Window, Right	Qty - 1
Quarter Window, Left	Qty - 1
Rear Window	Qty - 1
Bow Tie Down Strap	Qty - 2
Soft Header Trim	Qty - 1
Hard Pillar Trim	Qty - 1

## Parts List and Hardware Identification

Header Retainer, Qty - 1, Part Number 440.73

Header, Qty - 1, Part Number 440.72

Front Upper Rail - Lt., Qty - 1, Part Number 434.99

Front Upper Rail -Rt., Qty - 1, Part Number 434.98

Front Side Bow, Qty - 2, Part Number 435.04

Rear Side Bow, Qty - 2, Part Number 435.06

#2 Bow, Qty - 1, Part Number 443.99

Tailgate Retainer, Qty - 1, Part Number 440.94

C-Pillar Rail - Rt., Qty - 1, Part Number 435.02

C-Pillar Rail - Lt., Qty - 1, Part Number 435.03

Rear Upper Rail - Lt., Qty - 1, Part Number 435.11

Rear Upper Rail -Rt., Qty - 1, Part Number 435.10

#3 Bow, Qty - 1, Part Number 436.26

#4 Bow, Qty - 1, Part Number 436.27

Rail Connector - Lt, Qty - 1, Part Number 434.95

Rail Connector - Rt, Qty - 1, Part Number 434.94

Short Rail Bracket, Qty - 4, Part Number 471.36

Latch Spring, Qty - 2, Part Number 413.29

Header Knob Plate, Part Number 445.10, Qty - 2

Bow Mount Bracket - Lt., Qty - 1, Part Number 435.15

Bow Mount Bracket - Rt., Qty - 1, Part Number 435.14

Latch Backing Plate, Qty - 2, Part Number 442.68

Knob Bracket Assembly, Qty - 2, Part Number 471.13

Side Bow Pivot Link, Qty - 2, Part Number 401.41

C-Piillar Base - Lt, Qty - 1, Part Number 435.33

C-Piillar Base - Rt, Qty - 1, Part Number 435.32

Sunrider Latch - Lt, Qty - 1, Part Number 434.87

Sunrider Latch - Rt, Qty - 1, Part Number 434.86

Knob, Qty - 2, Part Number 316.85

Sunrider Base - Lt, Qty - 1, Part Number 434.91

Sunrider Base - Rt, Qty - 1, Part Number 434.90

# Supertop® with Tinted Windows – Installation Instructions

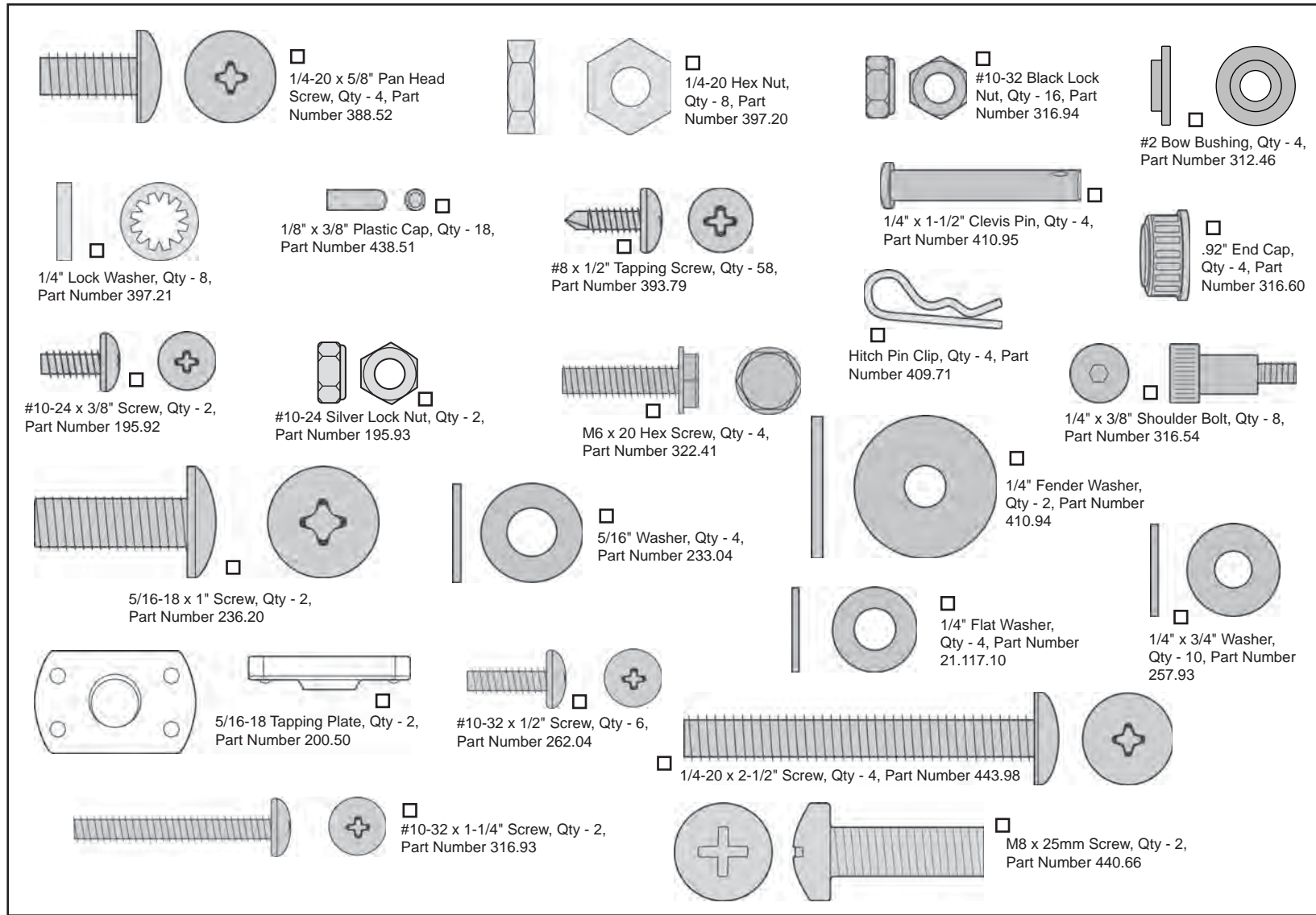

# Supertop® with Tinted Windows – Installation Instructions

## 1 Remove Quarter Windows and Rear Window

Refer to your owner's manual for instructions to remove any old hard or soft top components.

## 2 Install Bow Mount Brackets

Fold the hook and loop flap in the rear sport bar pad back and locate the tapped holes. Install the right and left Bow Mount Brackets on the sport bar with the M6 x 20 Hex Screws.

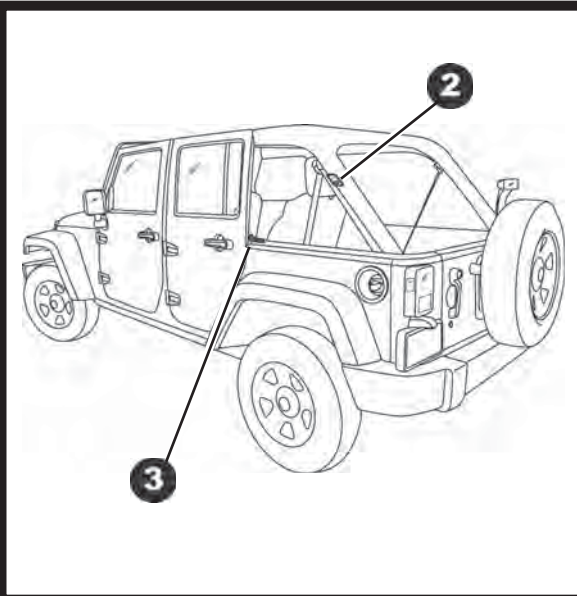
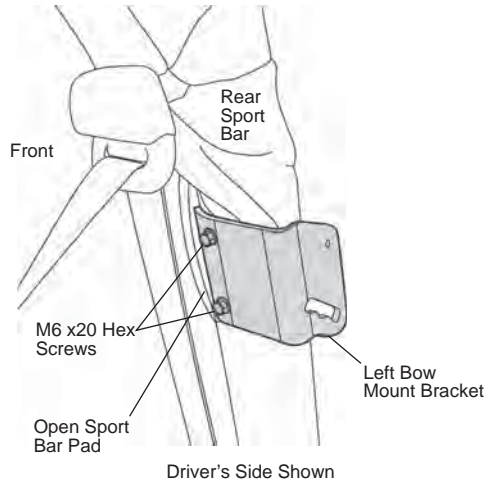

## 3 Install C-Pillar Bases

Place the C-Pillar Bases over the hole in the belt rail next to the rear door. Loosely install them with 5/16-18 x 1" Screws, 5/16-18 Tapping Plates and 5/16 Washers.

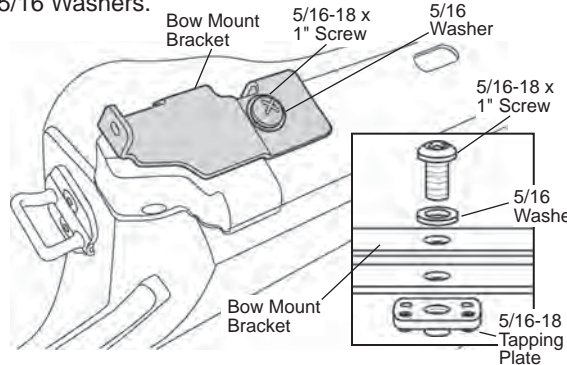

## 4 Install Rail Brackets on Front and Rear Upper Door Rails

Install a Rail Bracket in the inboard holes of each Front Upper Door Rail with #8 x 1/2" Tapping Screws.

Attach a Rail Bracket to the rear inboard holes of each Rear Upper Door Rail with #8 x 1/2" Tapping Screws. Leave the screws loose to be adjusted later.

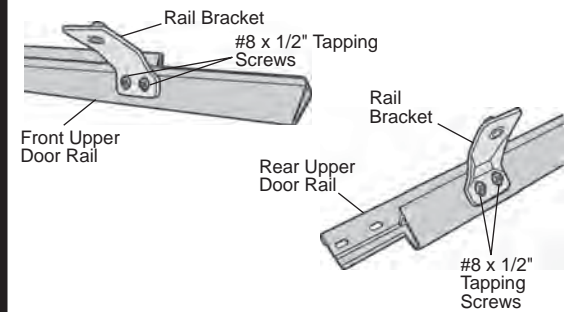

## 5 Assemble Sunrider Latches

Attach the Right Sunrider Latch to the Right Sunrider Base with a 1/4" x 3/8" Shoulder Bolt, two 1/4" Silver Washers and a #10-32 Black Lock Nut. Put one washer between the latch and the base and the other one behind the nut. Hook a Latch Spring into the hole in the latch and stretch it on to the notch in the base. Repeat on the left parts.

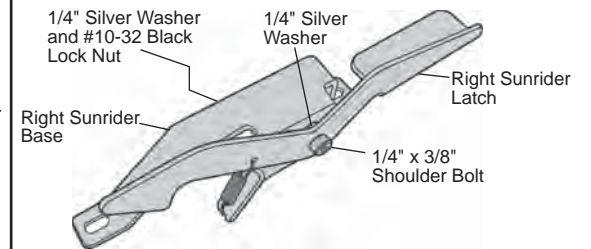

# Supertop® with Tinted Windows – Installation Instructions

## 6 Assemble Upper Door Rails

Attach each Sunrider Latch Assembly to the rearward set of holes on top of the Rear Upper Rails with two (2) #8 x 1/2" Tapping Screws each.

Connect the Rear Rails to the Front Rails Using the Right and Left Rail Connectors and four #8 x 1/2" Tapping Screws per side.

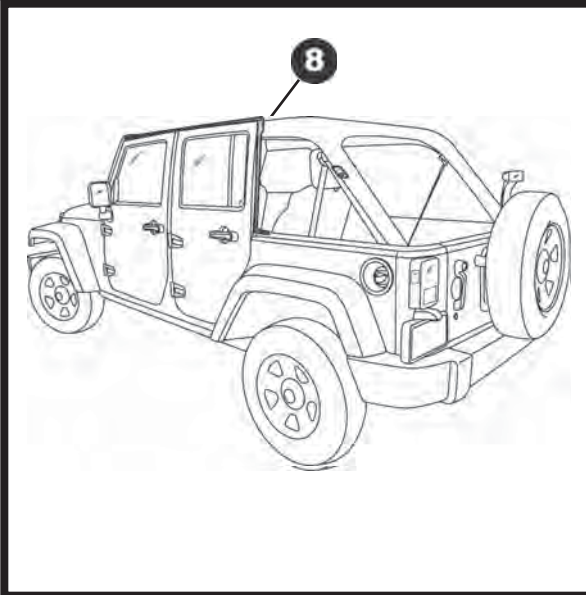
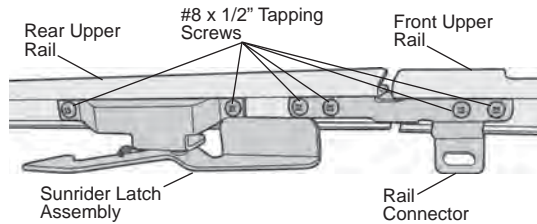

## 8 Install Door Rail Assemblies

Orient the Door Rail Assemblies on the vehicle with the Rail Brackets on top of the side sport bar and the C-Pillar Rails in front of the C-Pillar Base Brackets. Insert a 1/4-20 x 2-1/2" Screw with 1/4 x 3/4" Washer into the bottom hole and up through the top hole of the side sport bar. Use 1/4-20 Hex Nuts and 1/4" Lock Washers to secure the Rail Brackets. Attach each Rail Connector to the top of the B-Pillar with a M8 x 24 Screw and 5/16" Washer. Connect each C-Pillar Rail to the C-Pillar Base Brackets with 10-32 x 1/2" Screws and 10-32 Black Lock Nuts. Shut the door and adjust the rail position for the best fit and seal. Tighten all rail and Bow Mount Bracket fasteners. Push the Hard Pillar Trim groove over the inboard edge of the C-Pillar Rail. Trim excess and repeat on the other side.

## 7 Assemble Upper Door Rails to C-Pillar Rail

Attach the Left Rear Upper Door Rail Assembly to the Left C-Pillar Rail with two (2) #10-32 X 1/2" Screws and two black #10-32 Lock Nuts. Squeeze the C-Pillar Rail together with pliers until the nut is started if necessary. Leave fasteners loose for later adjustment. Repeat on the other side.

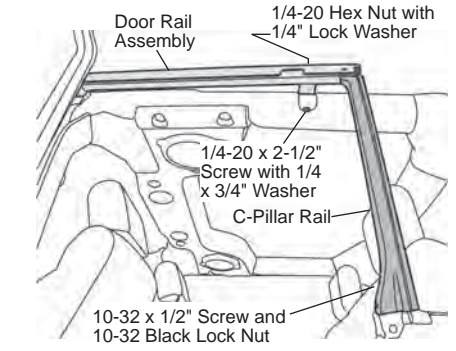
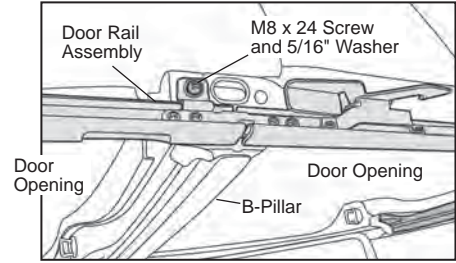
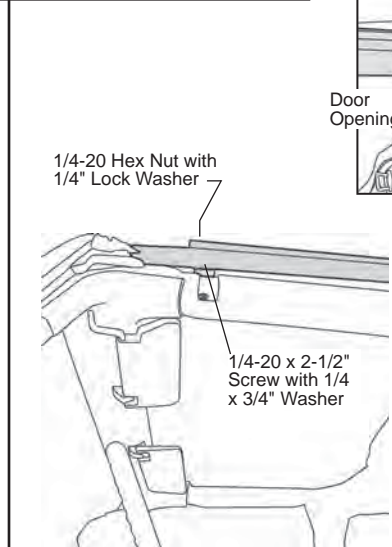
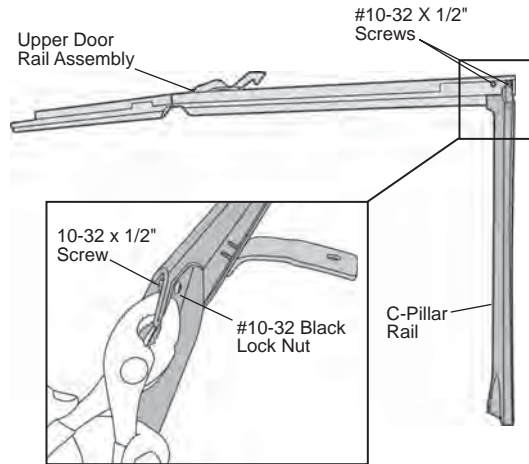

# Supertop® with Tinted Windows – Installation Instructions

## 9 Install Knob Bracket Assembly on Header

Orient a Knob Bracket Assembly with the threaded insert toward the front. Place it over a set of 1/4" holes on the rear flange of the Header. Mount it to the Header with two (2) 1/4-20 x 5/8" Pan Head Screws, a Backing Plate, a 1/4" Lock Washer, and 1/4-20 Hex Nut. Repeat with the other Knob Bracket Assembly.

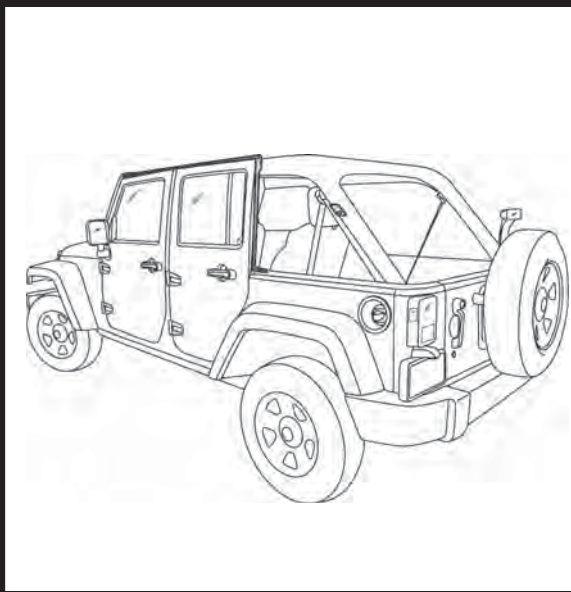
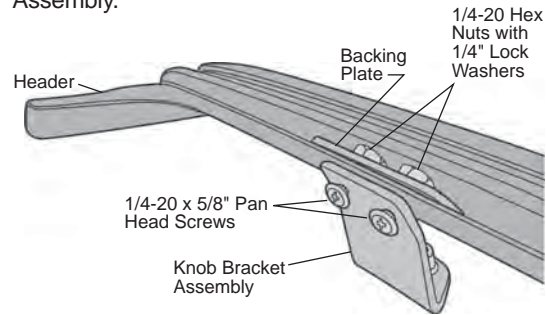

## 12 Install #2 Bow on Header Assembly

Place the #2 Bow on the Header/Side Bow Assembly so the plastic bow end is touching the Front Side Bow. Place Bushings on each side of the #2 Bow pivot hole and connect to the Rear Side Bow with a #10-32 x 1.25" Screw and #10-32 Black Nut. Repeat on the other side.

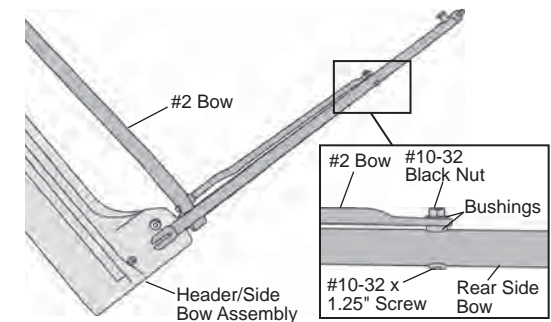

## 10 Assemble Side Bows

Orient the left Front and Rear Side Bow as shown with the Bushing in the rear bow pointing away from you. Place a Side Bow Link into the slot in the bow ends so the sharp corner is down and the rounded corner is up. Line up the holes and install a 1/4" x 3/8" Shoulder Bolt and #10-32 Black Nut. Assemble the right side bow in the same manner with the bushing pointing towards you.

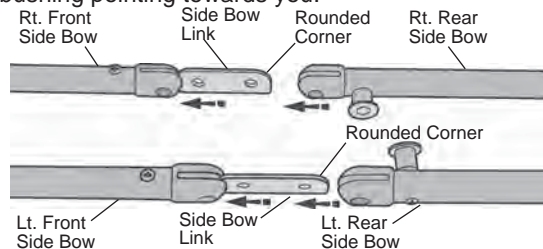

## 11 Install Side Bows on Header

Orient the left Side Bow Assembly under the left side of the Header so the Rear Side Bow is on top and the bushing points toward the center of the header. Install the Front Side Bow in the left outboard holes in the Header with two (2) #8 x 1/2" Tapping Screws. Repeat on the other side.

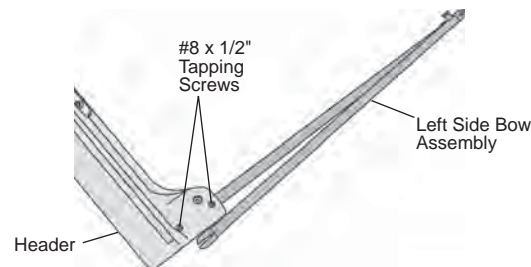

## 13 Install #3 Bow on Header Assembly

Tap an end cap into each end of the #3 Bow. Lay it on top of the Header/Bow Assembly so the tabs on the bow are pointing down. Connect each tab to the end of the Rear Side Bows with a 1/4" x 3/8" Shoulder Bolt and #10-32 Black Nut.

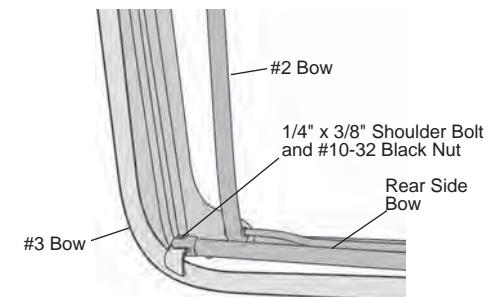

## Supertop® with Tinted Windows – Installation Instructions

### 14 Install #4 Bow

Tap an End Cap into each end of the #4 Bow. Position it next to the Bow Mount Brackets so the holes on the ends of the bow are outboard of the slot in the bracket. Connect the bow to the bracket with a 1/4" Clevis Pin, 1/4" Fender Washer between the bow and the bracket, 1/4" x 3/4" Black Washer, and Hitch Pin Clip.

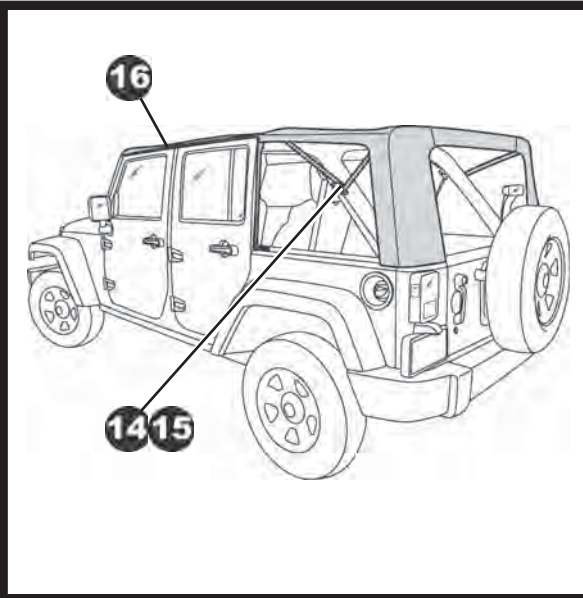
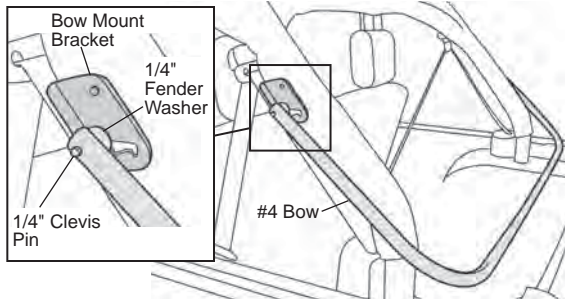

### 16 Secure Top Fabric to Header and Header Retainer

Push the Soft Header Trim groove over the leading edge of the header. Trim off any excess trim. Tape the trim to the header every 4". Slide the front pocket of the Top Fabric over the front edge of the Header. Position top fabric on the header so the welt on the fabric edge is against the step in the header. Center the fabric on the header and hold in place with masking tape. Lay the Header Retainer on the Header and position it so the fabric welt is captured between the Header and the Retainer. Line up the holes and attach the Retainer to the Header with eighteen (18) #8 x 1/2" Tapping Screws. Attach the Retainer to each Side bow with four (4) #8 x 1/2" Tapping Screws.

### 15 Install Header / Bow Assembly on Vehicle

Lay the Header/Bow Assembly on top of the #4 Bow with the #3 Bow facing forward. Orient one end of the #3 Bow so it is outboard of the Bow Mount Bracket. Place one (1) 1/4" Washer between the bow and bracket and install a 1/4" Clevis Pin with another 1/4" Washer between the bracket and the Hitch Pin Clip. Repeat this on the other side of the vehicle.

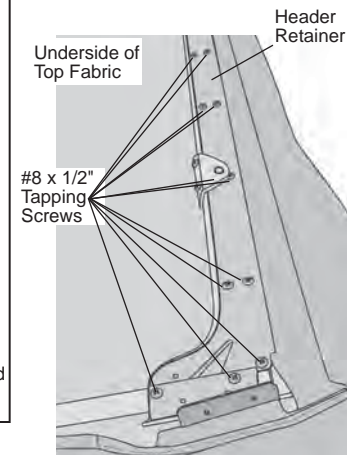
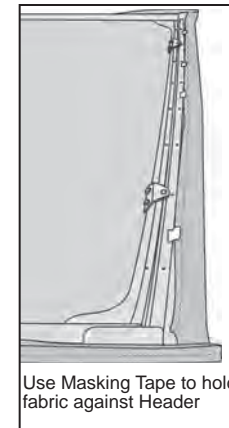
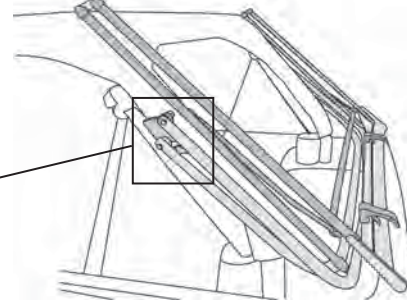
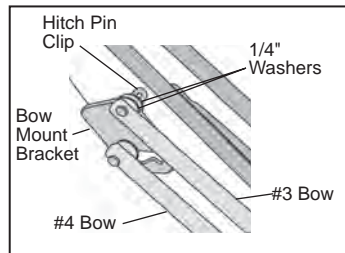

# Supertop® with Tinted Windows – Installation Instructions

## 17 Secure Header Retainer

Flip the fabric over to access the Header. Secure the right and left rear corners of the retainer to the Header with two (2) #10-24 x 3/8" Screws and #10-24 Silver Hex Nuts. Push a 1/8" x 3/8" Plastic Cap onto the points of each of the tapping screws.

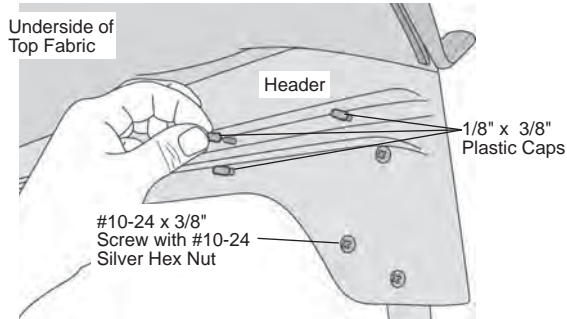

## 18 Secure Top Fabric Retainer to Header Retainer

Fold the front corner of the fabric around the header. Insert a #1 Phillips Screwdriver into the rear hole in the deck retainer and into the header retainer. Use the Screwdriver as a pry bar to stretch the deck rearward until the front retainer holes line up. Attach each deck retainer to the header retainer with two (2) #8 x 1/2" Tapping Screws.

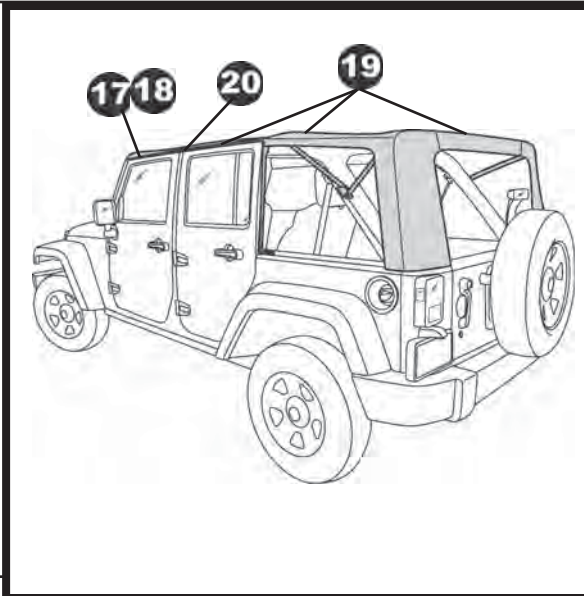
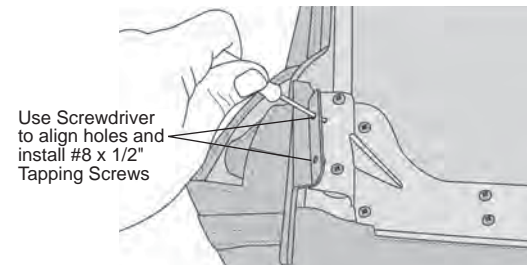

## 19 Secure Top Fabric to Bows

Raise the header slightly and locate the hook and loop bow flap. Wrap the flap around the #2 Bow and fasten the hook and loop. Locate the long fabric bow flap and position the flap holes over the holes in the #3 Bow. Secure the flap to the bow with four (4) #8 x 1/2" Tapping Screws. Locate the four (4) fabric tabs near the rear of the Top Fabric. Fasten the tabs to the #4 Bow with four (4) #8 x 1/2" Tapping Screws.

## 20 Secure Sunrider Latches

Open the top and lift it over the rear cab of the vehicle. Hook each Sunrider Latch securely over each Rear Side Bow Bushing.

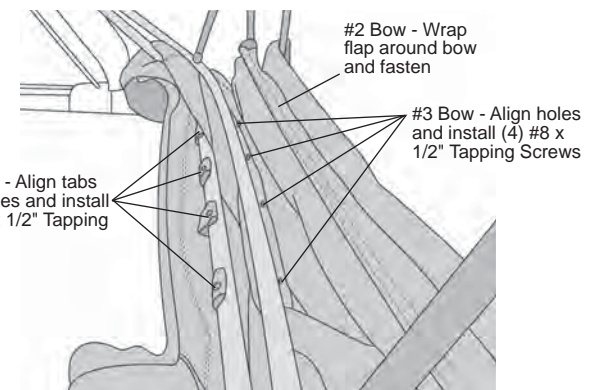
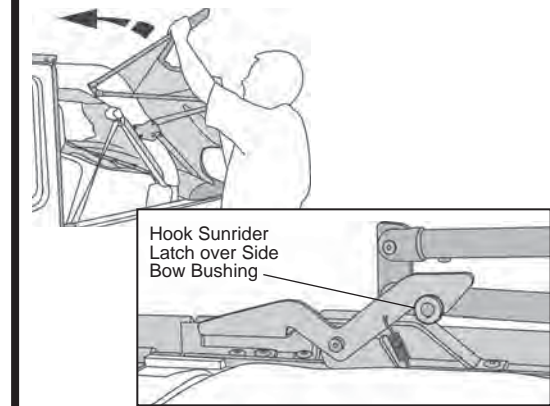



# Supertop® with Tinted Windows – Installation Instructions

## 21 Secure Header to Windshield

Lift the Header in the center and rotate it to the windshield. Insert a Knob through a Header Knob Plate so the cup in the plate faces up. Guide the Knob between the windshield and the footman loop and thread it into the insert of the Knob Bracket Assembly. Repeat on the other side. Alternate tightening the Knobs while keeping the Header centered until the Knobs are tight.

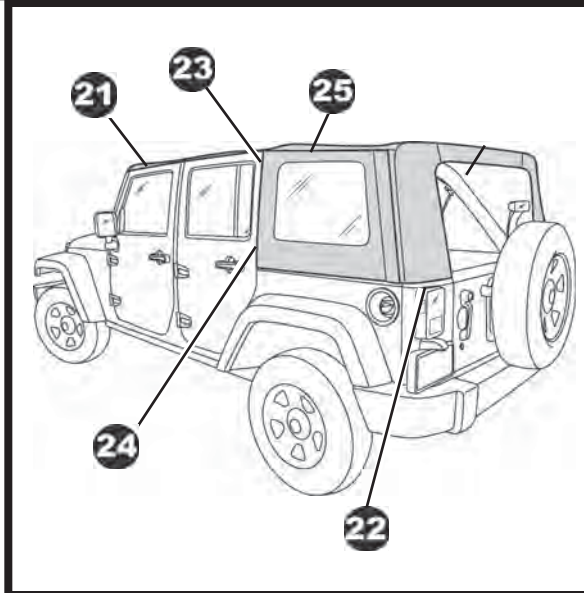
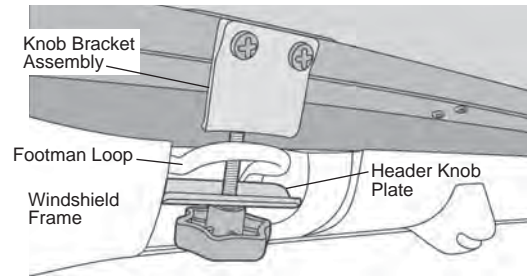

## 24 Secure Front of Quarter Window

Roll the plastic strip along the front of the Quarter Window into the channel in the Door Surround.

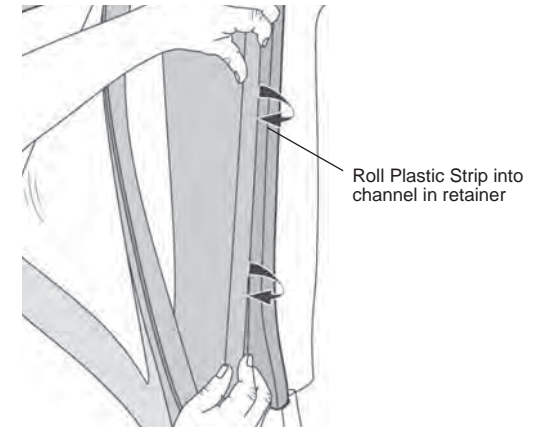

## 22 Secure Rear Corners

Make sure the #4 bow is at the forward end of the Bow Mount slot. Insert the plastic strip in the rear corner of the top into the channel in the body.

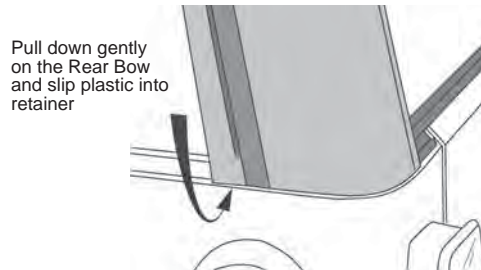

## 23 Attach Quarter Window Zippers

Start the zipper on the Quarter Window and close it 1-2 inches.

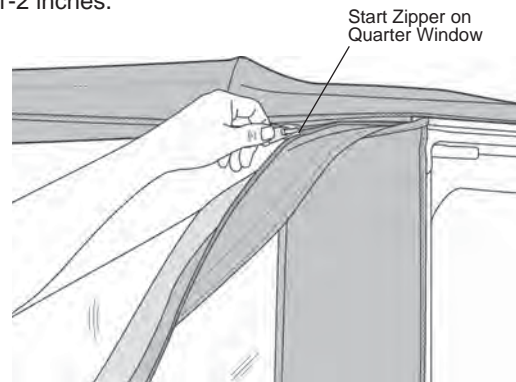

## 25 Secure Quarter Window

Close the zipper and slip the plastic along the bottom of the Side Window into the channel on the vehicle. Fasten the hook and loop strip above the window to the top.

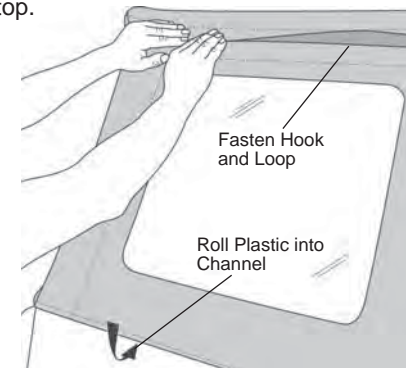

# Supertop® with Tinted Windows – Installation Instructions

## 26 Secure Top above Door Openings

Slip the plastic strips above the doors into the channel on the vehicle.

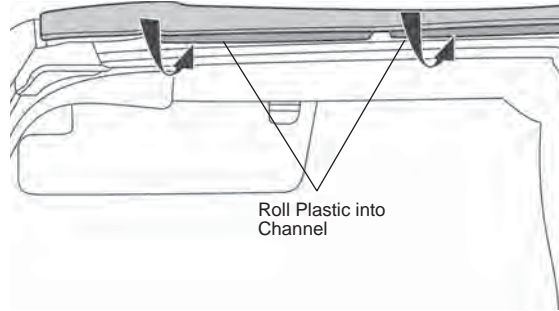

## 27 Install Tailgate Retainer on Rear Window

Remove the Rear Window from the box and lay it flat with the backing side up. Locate the Tailgate Retainer. The bar has a “C” shaped channel, when viewed from the end. Orient the retainer with the round seal down and slide the “C” channel on the retainer onto the tubed strip sewn to the backing side of the Rear Window.

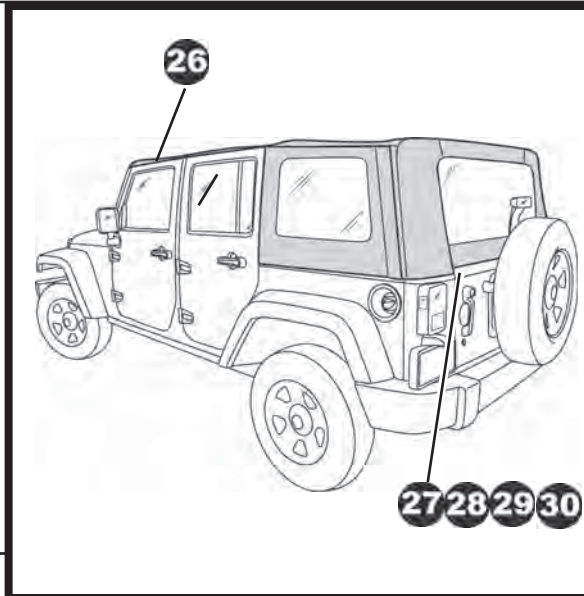
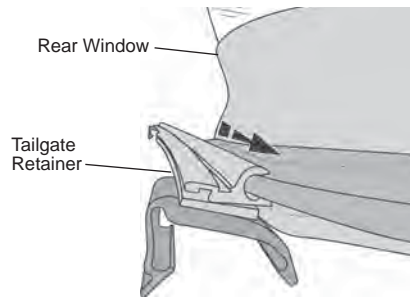

## 28 Install Tailgate Retainer on Vehicle

Hook the bottom of each clip on the bottom of the Tailgate Retainer under the rear edge of the belt rail. Roll the retainer toward the inside of the vehicle until it clips into place.

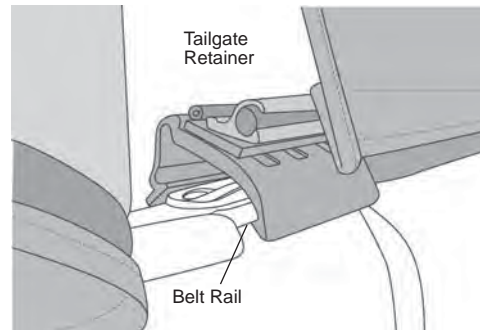

## 29 Secure Rear Window Zippers

To start the zipper, pull the two sliders as far down as possible on the driver’s side of the window in order to catch the sliders to the pin.

Once the zipper is caught, start the top slider 1/2". Then hold up the top of the window with one hand and close the zipper with the other. The zipper is sandwiched between layers of fabric in the corners so be careful not to catch extra fabric in the zipper. Close the zipper.

Make sure that the Tailgate Bar is centered and is securely in the mounts. Then tuck the flaps on the Rear Window under the top fabric.

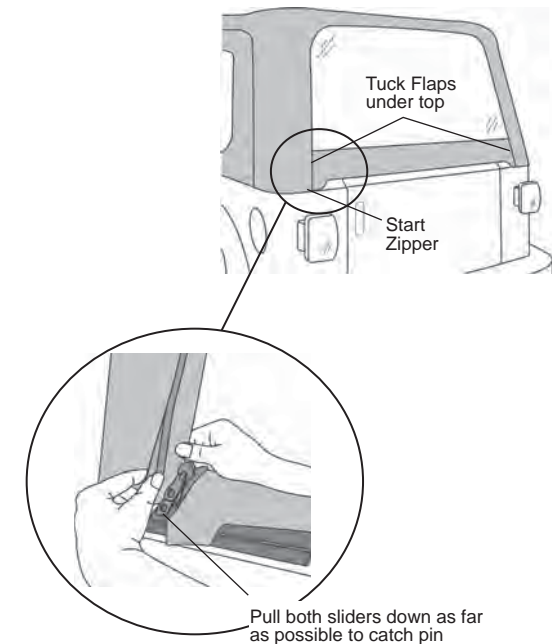

## Supertop® with Tinted Windows – Installation Instructions



### WARNING

When operating the vehicle without the Quarter Windows, remove the Rear Window for proper ventilation.

### 30 To Fold the Top Down Remove Quarter Windows and Rear Window

Remove the Quarter Panels and the Rear Window. Release the plastic strip from the retainer along the bottom and front of the panel

To roll up the Rear Window, remove the Tailgate Bar and open the zippers on each side of the window to the top. Start at the bottom and roll the window to the inside. Avoid wrinkles in the fabric and window. Secure it in place with the elastic garters inside of the top.

### 31 To Fold the Top Down Collapse Top

Release the front of the top from the windshield. Raise the front of the deck and collapse the rear bows, tucking the two plastic strips above the door openings inside of the bows, Wrap the fabric around the bows, then tuck the rear legs of the top under the bows.

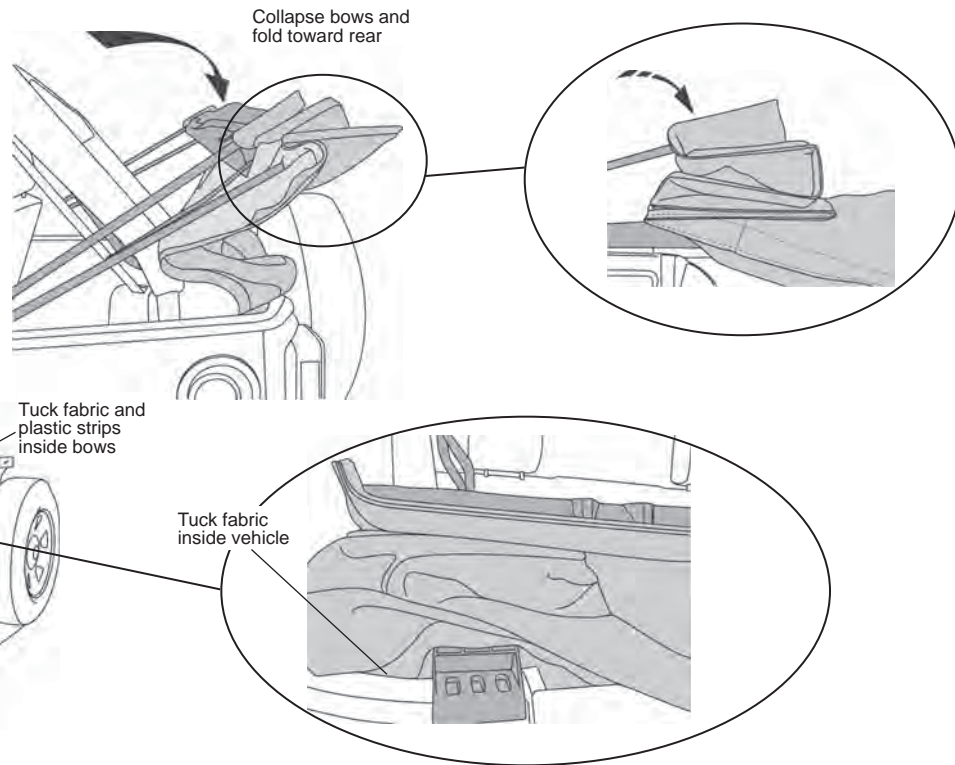

## Supertop® with Tinted Windows – Installation Instructions

---

### **32** To Fold the Top Down Secure Bows

Secure the bows to the sport bar when the top is down with the two Bow Tie Down Straps. Buckle the straps around the sport bar for storage when the top is in the up position.

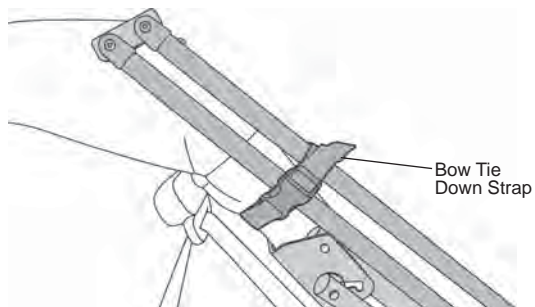

# Supertop® with Tinted Windows – Installation Instructions

## Care and Maintenance of your Bestop Product

Your Bestop product is made of the finest materials available. To keep it looking new and for the maximum possible wear, it will need periodic cleaning and maintenance.

**Washing:** The fabric should be washed often using soap, warm water and a soft bristle brush. Rinse with clear water to remove all traces of soap or use Bestop-recommended Bestop Cleaner and Bestop Protectant. Bestop Cleaner and Bestop Protectant are specially formulated to provide a total cleaning and protection system. Bestop Cleaner will not harm vehicle finish, is biodegradable and environmentally friendly. Bestop Protectant protects against UV-fading, cracking and hardening.

**Windows:** Keep windows clean to avoid scratching. DO NOT use a brush on the windows! Wash with a water-soaked cloth or sponge and a mild dishwashing detergent or use Bestop-recommended Bestop Vinyl Window Cleaner, which safely cleans and protects vinyl windows while helping prevent UV damage. NEVER WIPE THE WINDOWS WHEN THEY ARE DRY. Be careful when cleaning snow or frost from the vinyl windows since they are easily scratched and may crack at low temperatures. DO NOT roll the sides or rear window in cold weather. The windows become stiff and will crack.

**Zippers:** Keeping the zipper cleaned and lubricated with a silicone lubricant will help prevent damage and keep the zippers in a smooth working condition. If a zipper opens behind the slider, the slider may have been spread apart. This problem can usually be repaired by using an ordinary pair of pliers to bring the sides back into parallel. Return slider to the end of the zipper in the normal Open position. Squeeze lightly at first and test the zipper. If the zipper continues to remain open squeeze more firmly with the pliers and try the zipper again. Repeat this procedure until the zipper operates correctly.

**Water:** Seeping through at the seams may be stopped by applying 3-M Scotchgard® on the inside of the seams. Rips in the fabric may be repaired with Bondex® iron on patches. Iron the patches to the Inside of the top, carefully following the Bondex® instructions.

**Snaps:** Keep snaps cleaned and lubricated with silicone to help prevent snaps from sticking to the studs. If a snap does become stuck to a stud, use a screwdriver and GENTLY pry apart to prevent permanent damage to the snap or the top fabric.

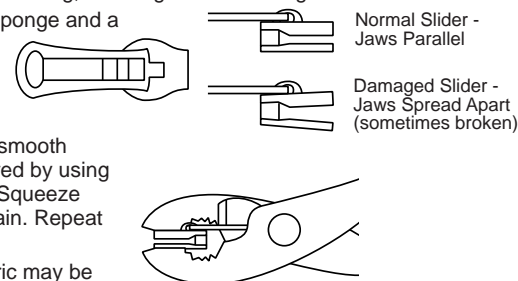

## LIMITED WARRANTY

We warrant our product to be free from defects in material and workmanship, for the terms specified below, provided there has been normal use and proper maintenance. This warranty applies to the original purchaser only. All remedies under this warranty are limited to the repair or replacement of any item or items found by the factory to be defective within the time period specified. If you have a warranty claim, first you must call our factory at the number below for instructions. You must retain proof of purchase and submit a copy with any items returned for warranty work. Upon completion of warranty work, if any, we will return the repaired or replaced item or items to you freight prepaid. Damage to our products caused by accidents, fire, vandalism, negligence, misinstallation, misuse, Acts of God, or by defective parts not manufactured by us, is not covered under this warranty.

THE WARRANTY TIME PERIOD IS AS FOLLOWS FOR REPLACE-A-TOP™, SAILCLOTH REPLACE-A-TOP™, SUPERTOP®, SUPERTOP® REPLACEMENT SKINS, SUNRIDER®, AND TIGERTOP®: TWO YEARS FROM DATE OF PURCHASE.

THE WARRANTY TIME PERIOD IS AS FOLLOWS FOR ALL OTHER “SOFT GOODS” MANUFACTURED BY OUR COMPANY (USING PRIMARILY VINYL, PLASTICS, AND/OR FOAM): ONE YEAR FROM DATE OF PURCHASE.

THE WARRANTY TIME PERIOD IS AS FOLLOWS FOR ALL OTHER “HARD GOODS” MANUFACTURED BY OUR COMPANY (USING PRIMARILY METALS, PLASTICS, AND/OR FIBERGLASS): ONE YEAR FROM DATE OF PURCHASE.

ANY IMPLIED WARRANTIES OF MERCHANTABILITY AND/OR FITNESS FOR A PARTICULAR PURPOSE CREATED HEREBY ARE LIMITED IN DURATION TO THE SAME DURATION AND SCOPE AS THE EXPRESS WRITTEN WARRANTY. OUR COMPANY SHALL NOT BE LIABLE FOR ANY INCIDENTAL OR CONSEQUENTIAL DAMAGE.

Some states do not allow limitations on how long an implied warranty lasts, or the exclusion or limitation of incidental or consequential damages, so the above limitations or exclusions may not apply to you. This warranty gives you specific legal rights, and you may also have other rights which vary from state to state.



For further information or request for warranty work, please contact:

Bestop Inc., Customer Service

Toll-Free: (800)845-3567

Main: (303)465-1755

E-mail: [csbestop@Bestop.com](mailto:csbestop@Bestop.com)

Website: [www.Bestop.com](http://www.Bestop.com)