

OWNER'S MANUAL



HARD ROLLING TRUCK BED COVER

Customer Service Phone: (1-800-449-6649) Fax: (844) 270-0593 Phone: 770-614-6101

P/N 1118398 Rev A

FIVE YEAR WARRANTY

Rugged Ridge warrants that all new, unused products are free from defects in material and workmanship. This Five year Limited Warranty is effective if the product is properly installed and used for the purpose intended. It applies to the original buyer only. Rugged Ridge's obligation under this Warranty is limited to repairing, or at its option, replacing any part that is returned, transportation prepaid, to Rugged Ridge, if the product is, in our judgment, defective. All materials must be accompanied by an RMA (Returned Material Authorization) number requested by and authorized in advance of returning the materials. Rugged Ridge shall not be liable or responsible to supply or pay labor to replace any part found defective, nor shall it be liable for any damages of any kind or nature to person, product, or property.

There are no Warranties for used products or products that have been repaired, altered, modified, subjected to misuse, negligence, accident or ordinary wear and tear.

Rugged Ridge products are sold without any express warranty except as set forth above. Rugged Ridge is not obligated to honor warranty claims if Genuine Rugged Ridge parts are not utilized.

DIRECT ALL WARRANTY CLAIMS TO RUGGED RIDGE

SAFETY INSTRUCTIONS

1. Do not place objects on or against cover or framework.
2. Do not tie cargo to truck bed cover framework.
3. **Never** allow children or pets to occupy pickup box while cover is closed.
4. Cover is not airtight. Special care is required to keep cargo clean and dry.
5. Fabric cover won't prevent theft of contents inside truck box.
6. Cover must be rolled fully open and secured with retainer straps when towing vehicle backwards.
7. **DO NOT** stow rolled cover against cab window.
8. **DO NOT ATTEMPT TO DRIVE WITH THE COVER IN THE PARTIALLY OPEN POSITION!**
9. **A FULLY ROLLED OPEN COVER MUST ALWAYS BE SECURED WITH RETAINER STRAPS.**
10. **DO NOT** operate vehicle with objects on top of the cover.

OWNER/USER RESPONSIBILITIES

It is the responsibility of the owner/user to read this manual and comply with the operating procedures. The owner/user is also responsible for inspecting the Rugged Ridge cover, and for having parts repaired or replaced when worn or damaged.

Failure to follow safety instructions and warning labels could result in failure of your cover system and/or personal injury.

MESSAGES TO INSTALLER

- Always wear safety glasses and/or other necessary protective equipment when installing your Rugged Ridge truck bed cover.
- These instructions are complete for most pickup models. Additional instructions are included, if required for your truck. Please read entire manual before installing your Rugged Ridge truck bed cover.

IMPORTANT OPERATING TIPS

- Truck bed cover must be free of foreign material including snow and ice before rolling cover open or closed.
- It is recommended to operate vehicle with cover rolled closed and latched for optimal fuel economy.
- Prolonged cold weather will make cover fabric stiff. Move vehicle with cover unrolled and latched into sun or indoors to warm the top surface.
- If cover has been stored in a rolled up state for a long period of time it may take few minutes for the cover to lay flat. The fabric material needs to relax to a flat state, this is normal.
- **DO NOT** roll cover into rear cab window. **DO NOT** stow against cab.

COVER CARE AND MAINTENANCE

1. Cover surface can be hand washed with mild soap and water or cleaned in a car wash. Thoroughly rinse cover to remove any soap residue. **Never use vinyl conditioners that contain silicon, petroleum, or citrus based products on your truck bed cover as they may crack and shrink the vinyl top surface.**
2. It is recommended that you periodically check that the cover is securely attached to your truck bed. Inspect the clamps and front header guide slides to ensure they were properly installed and have not come loose during operation.
3. It is recommended that you periodically inspect and service the rear latch closures. Clean away any excess dirt or grime and lubricate with silicone spray. Ensure the latches move freely in and out to properly engage the side rail and provide performance with optimal security. Be careful not to overspray the cover.

IMPORTANT INSTALLATION TIPS

- Modification of accessories such as bed liners (including spray in liners) may be necessary allowing the truck bed cover side rails to fit properly between the front bulkhead and tailgate of the truck bed.
- When placing the rolled up cover assembly on the side rails and installing it to the side rails (see step 15) the weight of the cover assembly may tilt or flex the rails downward. Simply push up on the rail when securing the header guides to the rail (see step 16).
- After the initial installation leave cover closed and latched for a 24 hour period. This will insure that the fabric has taken a complete set to the metal substrate.

ADDITIONAL IMPORTANT OPERATING TIPS

INCORRECT METHOD Of How To Open Cover To The Front.



****Do not slide a partially opened cover across the cover's surface.****

****Do not slide cargo across the cover's surface.****

****Do not store items on cover's surface.****

CORRECT METHOD Of How To Open Cover To The Front.

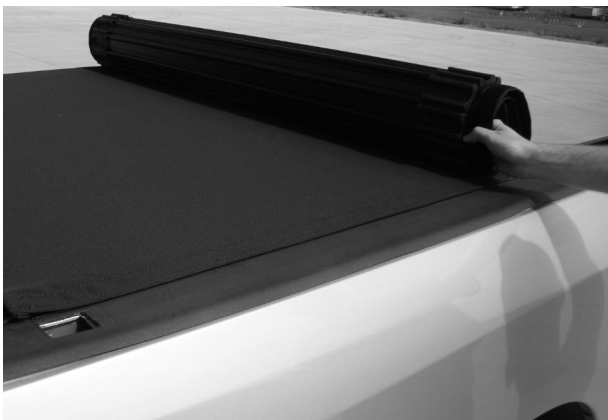

ADDITIONAL IMPORTANT OPERATING TIPS

AFTER INITIAL

Cover Tracking Marks: The cover will experience slight tracking marks from dust deposited on the top surface even after the first initial roll out. If there is a heavy deposit of dust, simply use a wet rag to wipe the top surface of the cover clean.

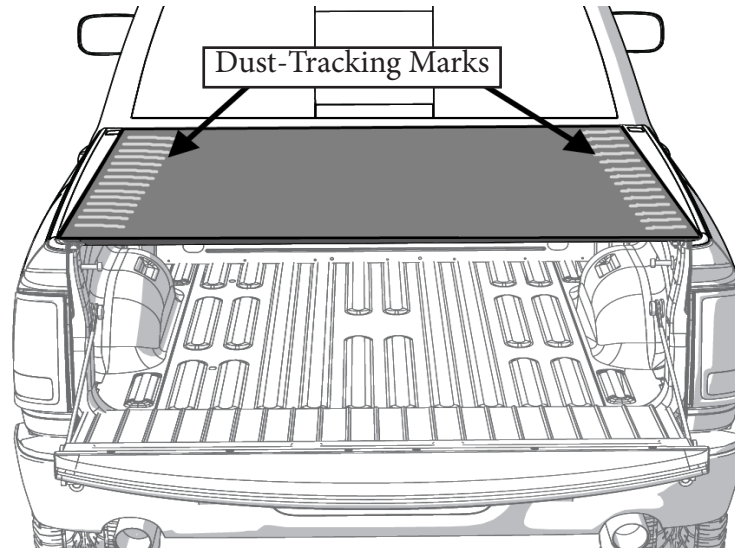

DAY TO DAY USE

Cover Tracking Mark Prevention: All truck beds will accumulate road dust. This dust will accumulate on the side rails and adhere to the underside of the truck cover. When the truck cover is rolled open, the underside of the cover can deposit dust onto the top surface. To prevent dust-tracking marks, periodically clean the side rail surfaces, rubber slat end caps, and underside surface of the cover to remove dust build up. Plugging air holes and gaps in the truck box construction will also greatly reduce dust intrusion into the truck box. Periodically cleaning the top surface with soap and water will also help prevent dust-tracking marks.

IMPORTANT OPERATING INSTRUCTIONS: SETTING THE HOOK AND LOOP BEFORE OPERATING

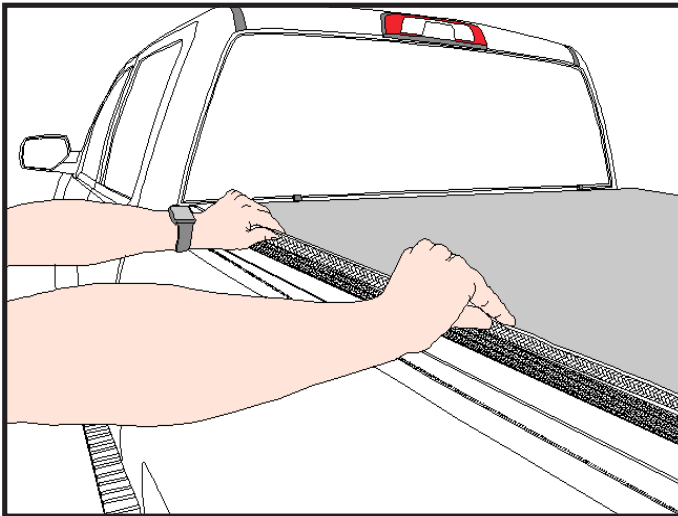

Engaging Hook and Loop, Step One: After rolling the cover closed, grab the fabric loop flap and evenly pull loop over the hook track engaging the loop to the hook track. **Avoid pulling fabric flap straight up.**

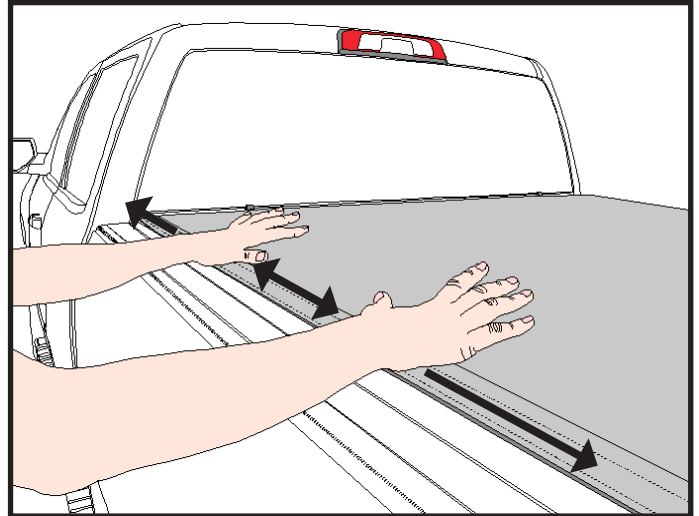

Engaging Hook and Loop, Step Two: With the cover closed and both hook and loop engaged, use the palms of your hand to firmly push the loop strip into the hook track. Do this to both driver and passenger side up and down the entire length of the loop seams.

HOOK AND LOOP MUST ALWAYS BE SET AFTER ROLLING COVER CLOSED!

ADDITIONAL IMPORTANT SAFETY TIPS



CAUTION HIGH TEMPERATURE

TOP SURFACE AND BOTTOM SURFACE CAN BECOME EXTREMELY HOT TO TOUCH WHEN EXPOSED TO BRIGHT SUN AND OR HEAT. **NEVER ALLOW CHILDREN OR PETS TO SIT ON COVER WHEN CLOSED OR ROLLED TO THE CAB.**



CAUTION

ROLL COVER TIGHT. SECURE THE COVER APPROPRIATELY USING BOTH RETAINER STRAPS. **DO NOT** OVERTIGHTEN. **DO NOT** STOW COVER AGAINST



CAUTION

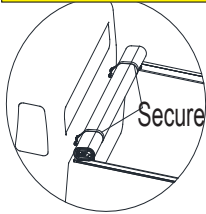

Before driving with cover open, **BOTH STRAPS MUST BE SECURED TO RETAINER LOOPS.** Failure to do so could cause accidental release of the cover, resulting in personal injury or property damage.

Components:

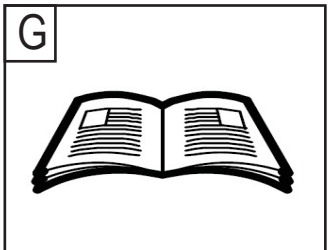
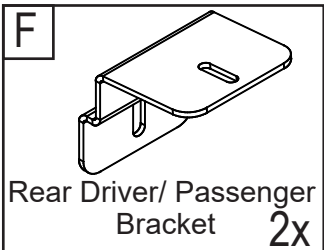
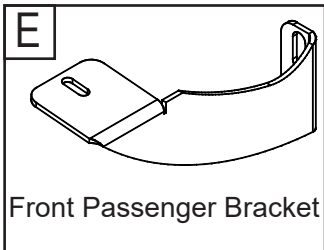
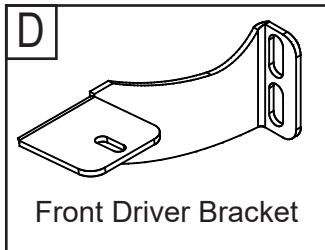
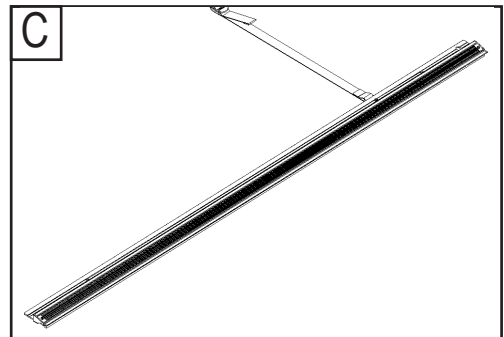
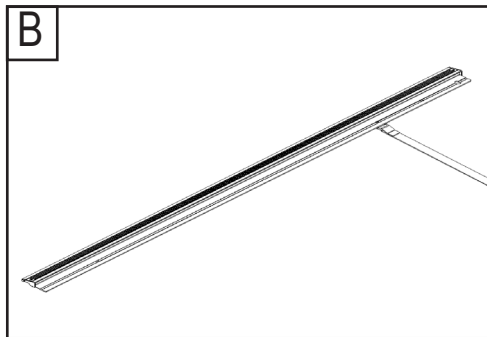
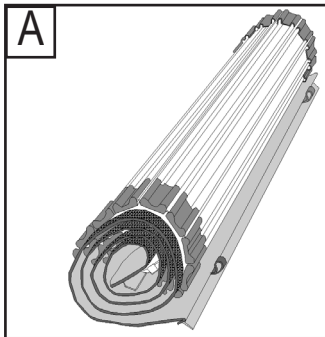

Tools Required

Correct

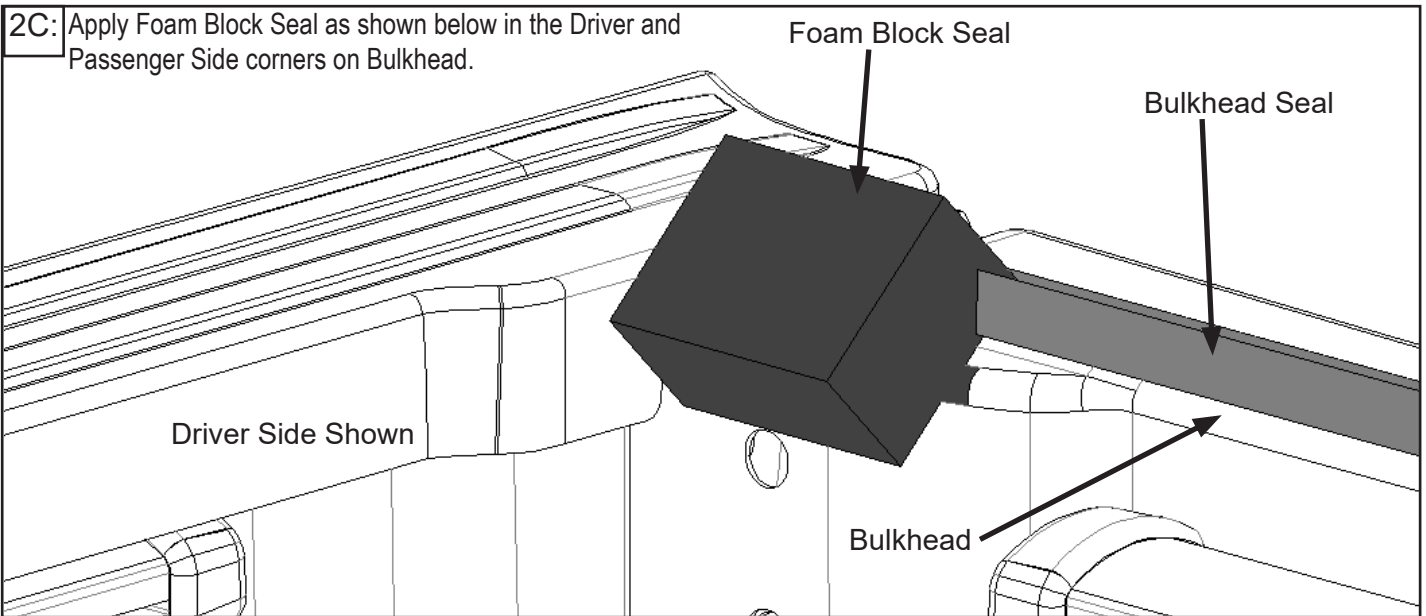
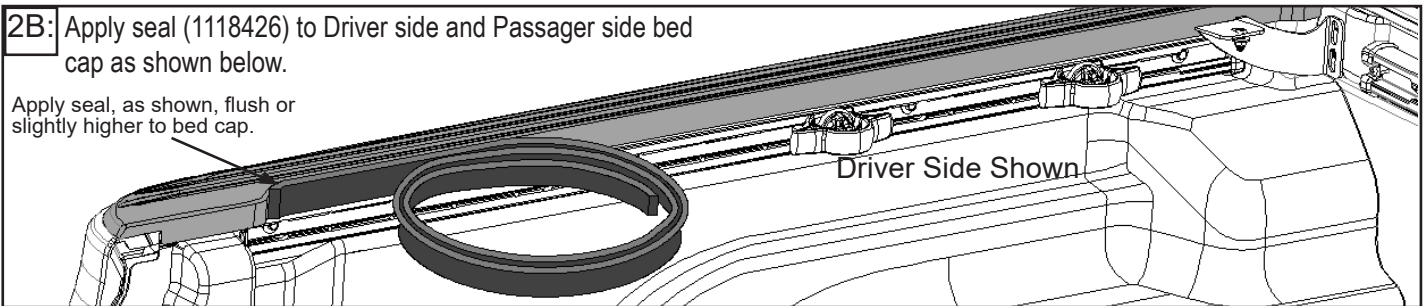
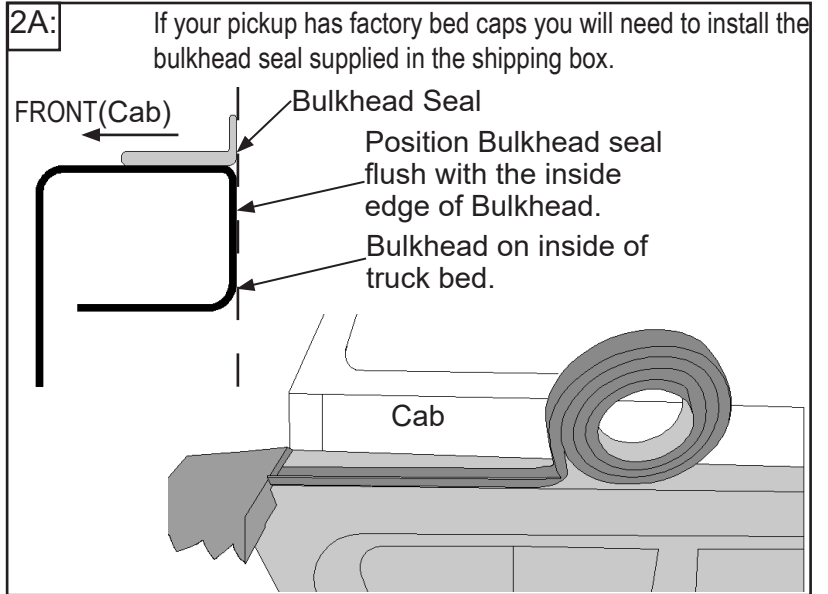
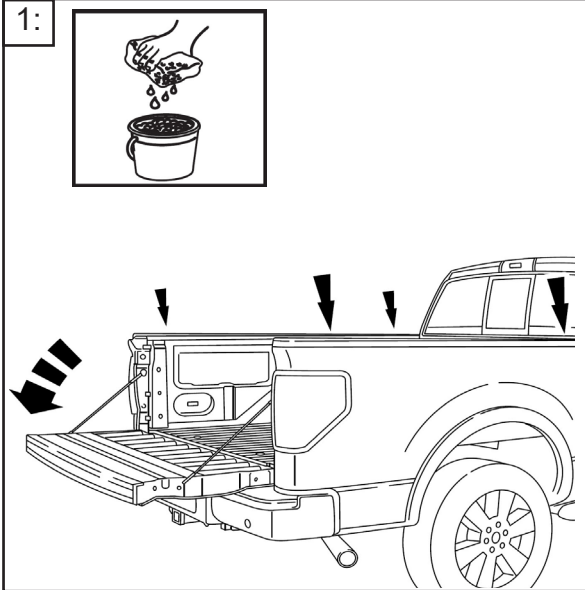

INSTALLING BRACKETS AND RAILS:

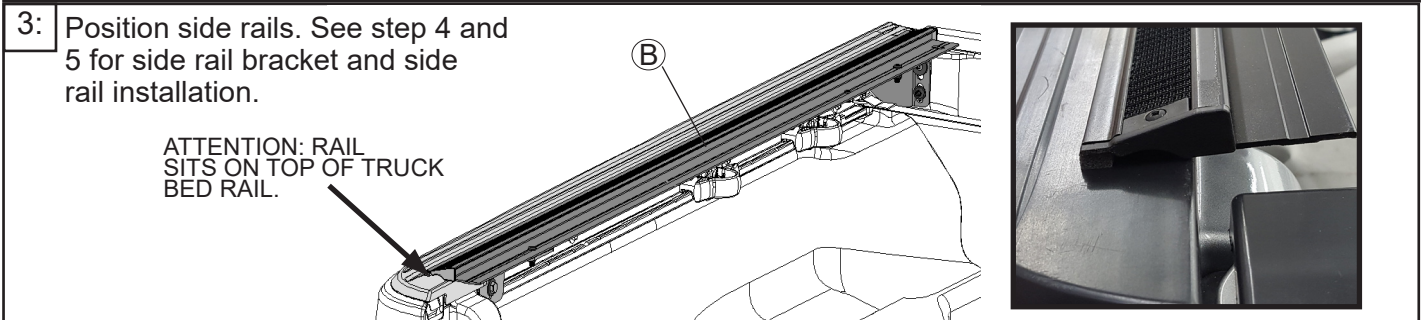

INSTALLING BRACKETS AND RAILS CONT:

4: Loosen both tie down anchors in each Trail Rail, slide them to the front of the cab and remove them from the Rail.

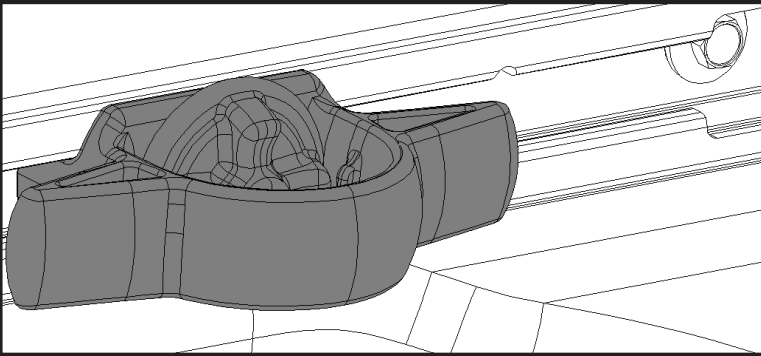

5: Tie down anchors will come out of the Trail Rail at location shown below.

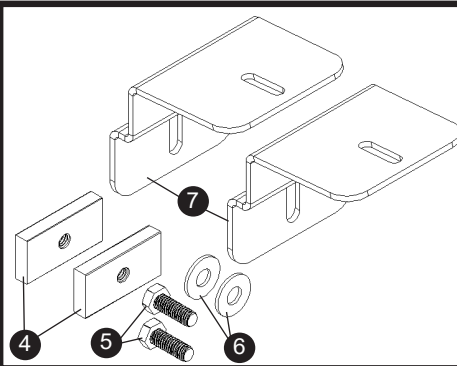
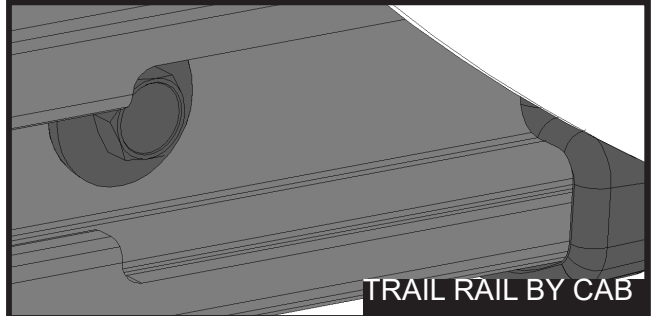

Item	Part #	Description
1.	1705596	BUTTON HEAD SCREW 1/4"-20
2.	1700427	FLAT WASHER 1/4" USS
3.	1701543	HEX NUT_FULL NYLON LOCK_1/4"-20
4.	1705880	5/16" RAIL SYSTEM NUT
5.	1705954	CAP SCREW HEX HEAD 5/16-18
6.	1700428	FLAT WASHER 5/16-18
7.	1706275	DRIVER/PASSENGER REAR BRACKET
8.	1706273	DRIVER FRONT BRACKET
9.	1706274	PASSENGER FRONT BRACKET
10.	1706277	CAP SCREW BUTTON HEAD M8
11.	1706278	CAP SCREW BUTTON HEAD 10-32
12.	1706279	WELL NUT 10-32
13.	1706347	FLAT WASHER

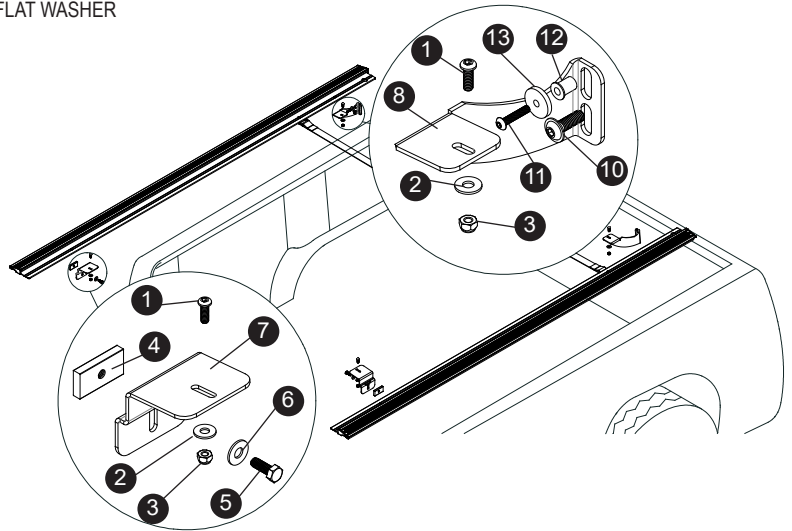
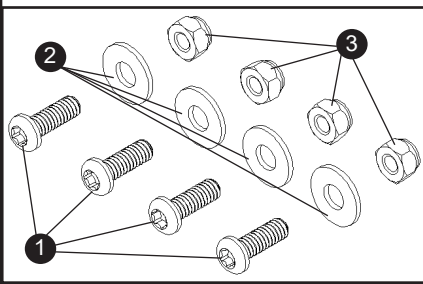
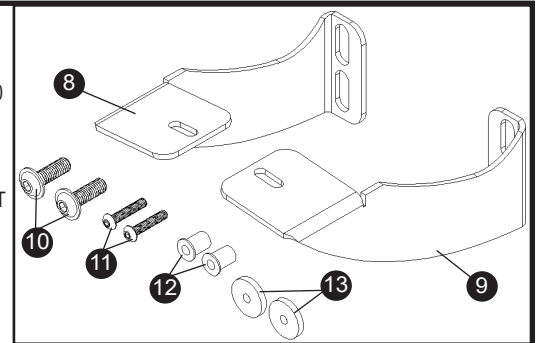

6A: Insert nut into Trail Rail system and slide nut to the rear of truck.

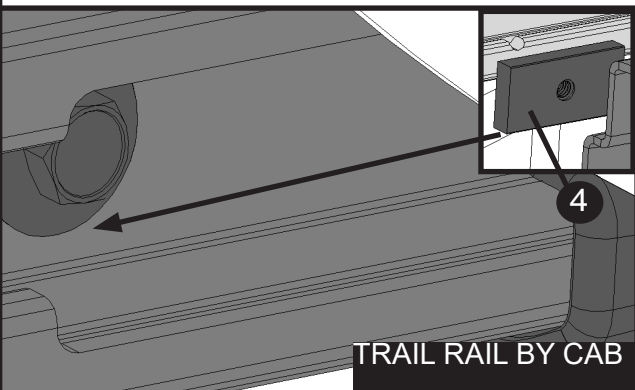

6B: Assemble bolt/washer and bracket as shown and leave loose at this time.

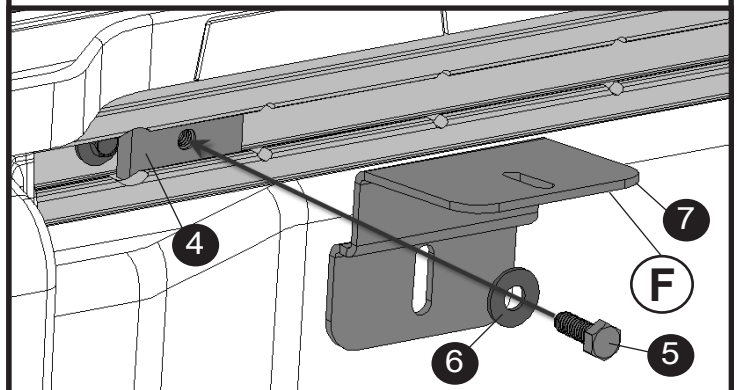

INSTALLING BRACKETS AND RAILS CONT:

ATTENTION:

At this time, reinstall the tie down anchors into the Trail Rail system that were taken out in Step 4.

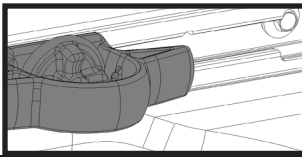

7: Assemble front bracket to Bulkhead as shown below while leaving bolts loose at this time.

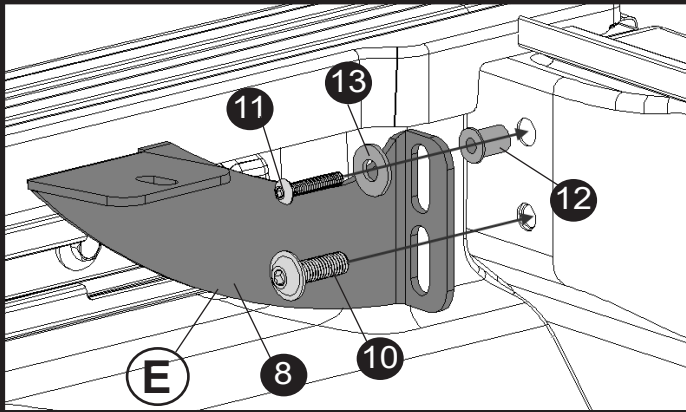

8: Locate the Mounting hole in rail at the front. Proceed by lining up that hole with the slot in the front bracket from step 7 and assemble hardware as shown.

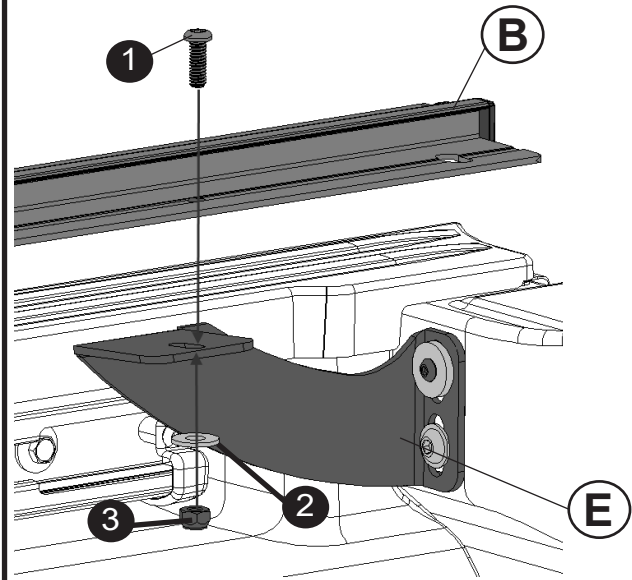

9: Locate the Mounting hole in rail at the rear. Proceed by lining up the mounting hole with the slot in rear bracket from step 6B and assemble hardware as shown.

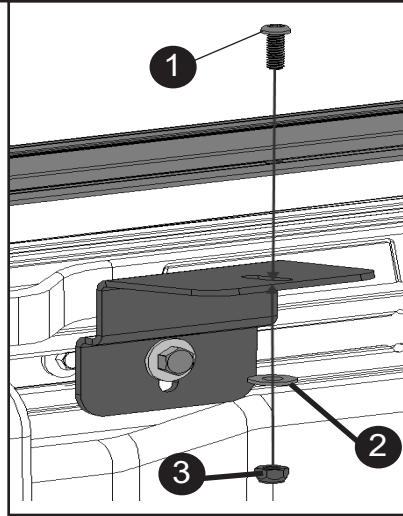

10: Apply pressure on the rail down and towards the outside of the bed while tightening the bolt to hold rail down to bracket.

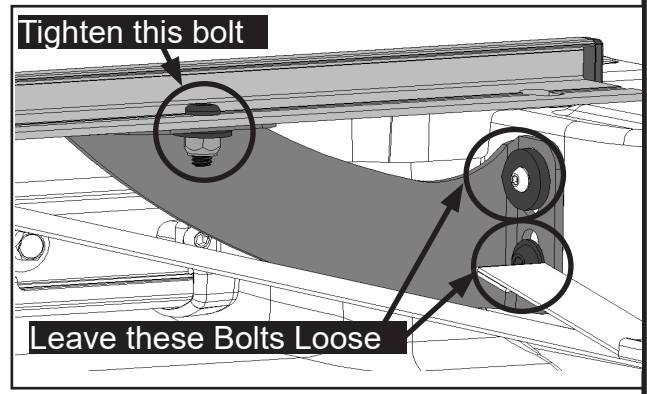

11: Apply pressure on the rail down and towards the outside of the bed while tightening the bolt to hold rail down to bracket.

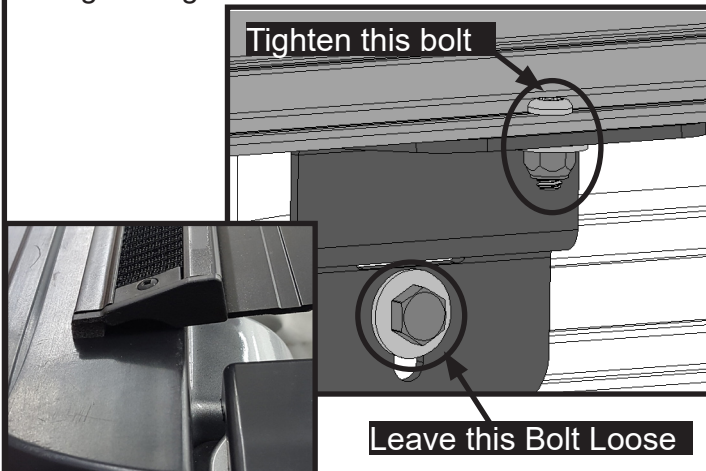

12: Apply pressure down on the rail and the bracket to compress the rail seal and tighten the two bolts that go into the front bulkhead.

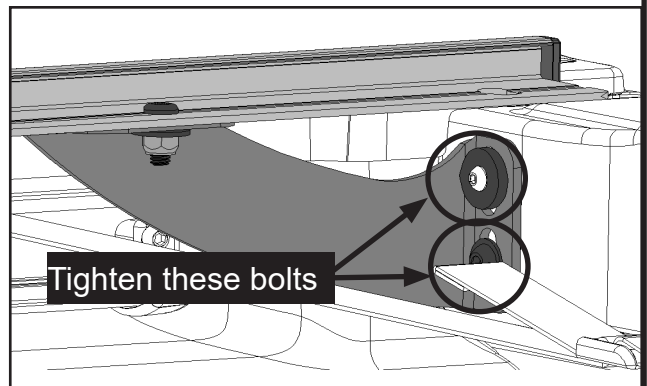

INSTALLING BRACKETS AND RAILS CONT:

13: Apply pressure down on the rail and the bracket to compress the rail seal and tighten the bolt.

Tighten this bolt

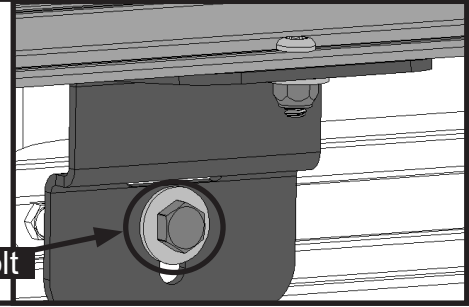

14: Repeat steps 4-13 on passenger side for item C. Proceed to step 15 when complete.

INSTALLING COVER ASSEMBLY:

15:

Note: The rail may need to be forced upward slightly to allow the screw head to drop in the slot.

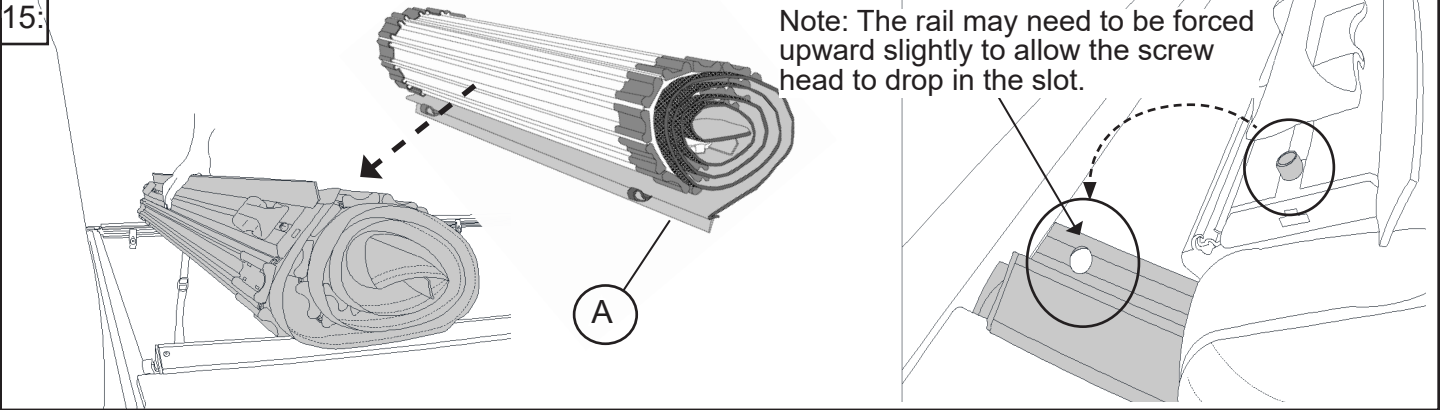

16:

Note: The rail may need to be forced upward slightly to allow the header guides to slide.

Note: The rail may need to be forced upward slightly to allow the header guides to slide.

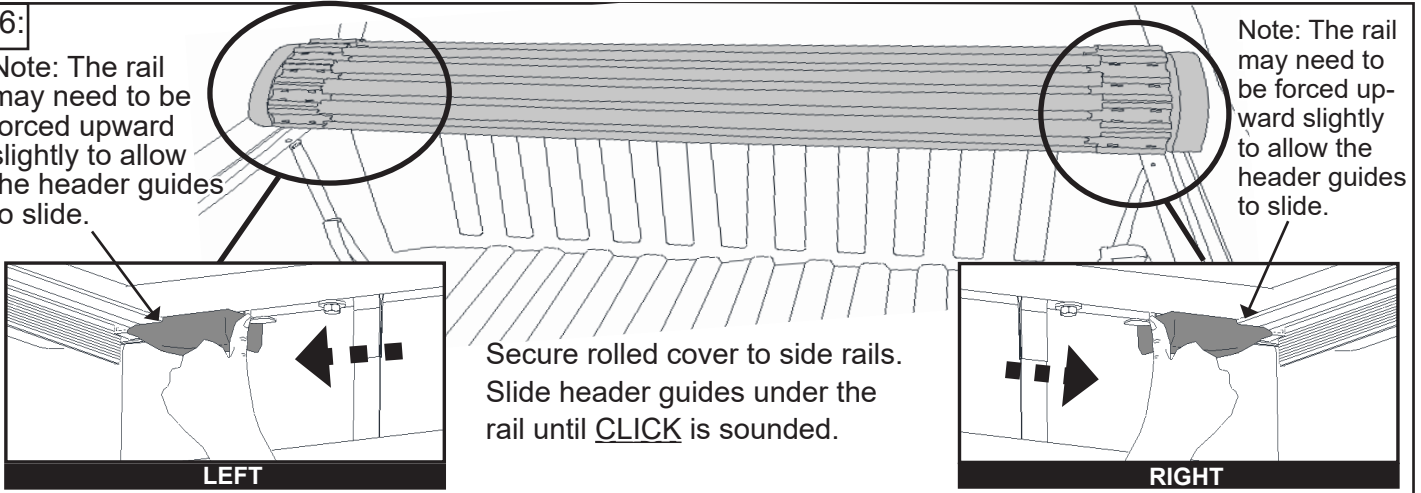

CLOSING THE COVER:

17:

Unroll cover to the tailgate.

CAUTION
PINCH POINTS
CAN CAUSE SERIOUS
PERSONAL INJURY

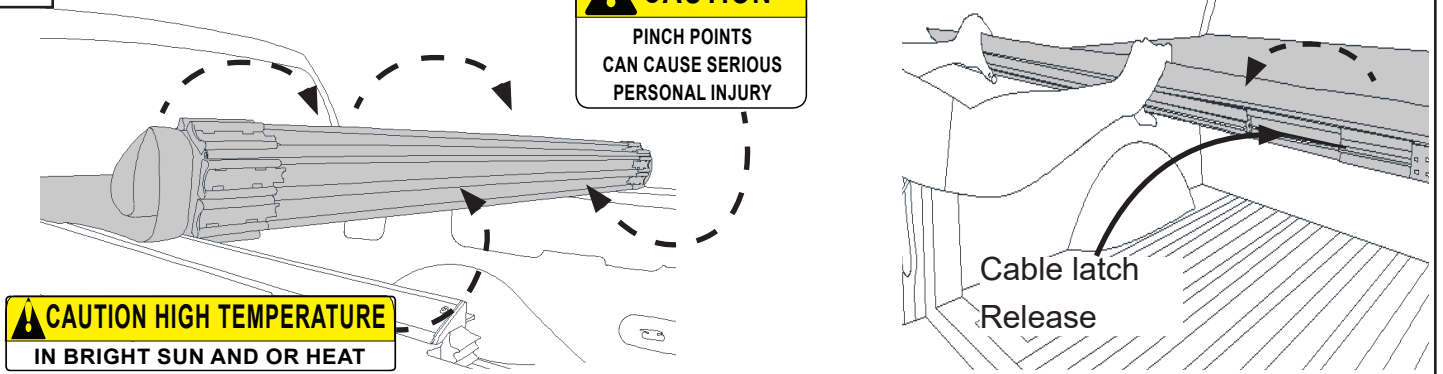

CLOSING THE COVER CONT:

18: Latch Both Sides.

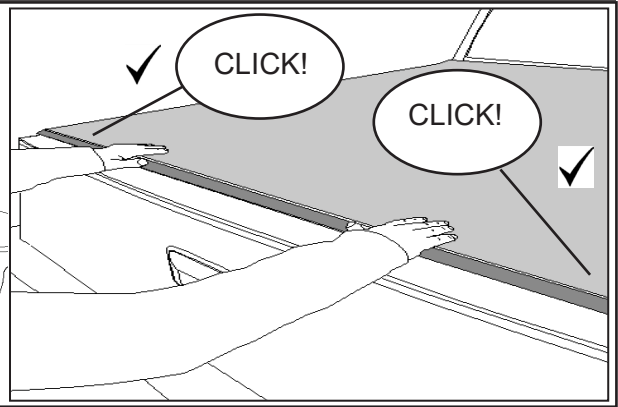
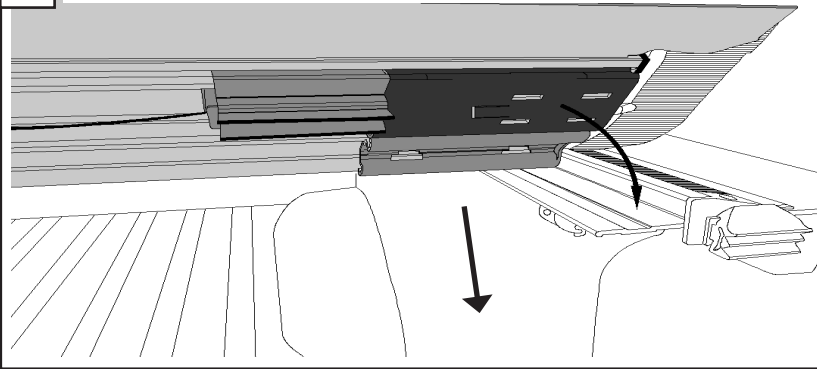

19: **PREFERRED METHOD OF CLOSURE:** Close tailgate, then close cover on top of tailgate. This method will not work with some truck applications. Use alternate method instead.

ALTERNATIVE METHOD OF CLOSING COVER: Close and latch cover, then close tailgate with the seal to the inside of the tailgate. Some care will need to be taken to train seal to be closed on the inside.

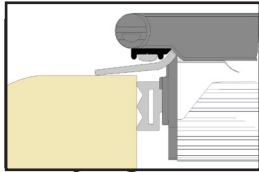

NOTE: If you have a key lock tailgate, truck bed cover is secured until tailgate is unlocked and opened.

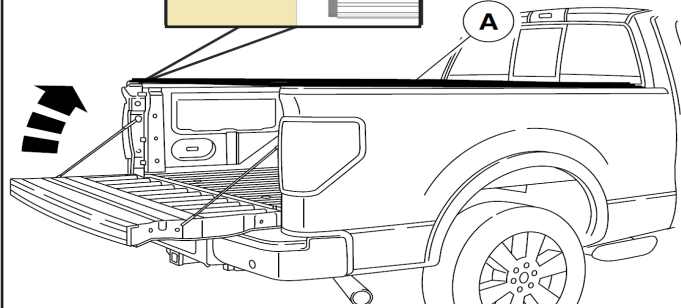

! Make sure cover is securely latched on both sides before operating vehicle.

SETTING HOOK AND LOOP FASTENER:

20: Secure Hook and Loop down both sides along entire length of cover system.

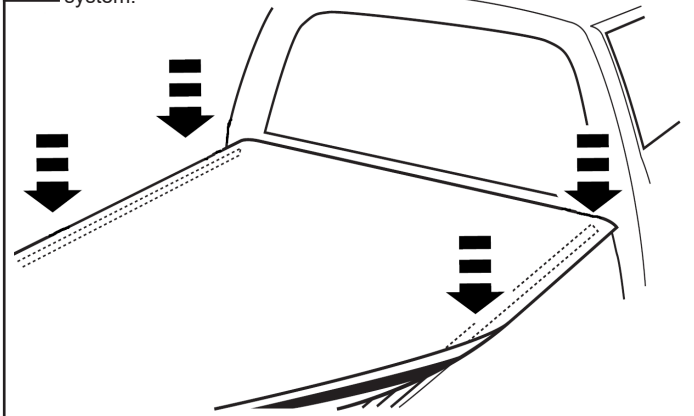

! **NOTE:** Secure hook fastener and loop fastener along entire length of both side rails before driving vehicle. This will prevent wind lifting the cover and causing damage.

ATTENTION!

After the initial installation leave cover closed and latched for a 24 hour period. This will ensure that the fabric has taken a complete set to the metal substrate.

OPENING THE COVER:

21: To open cover, pull down on release cable and hold down. Lift and roll rear header.

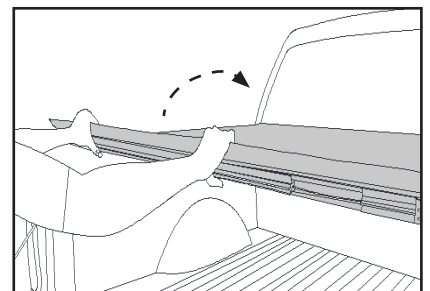
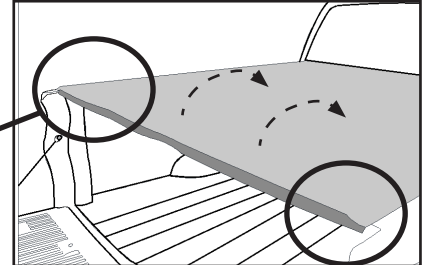
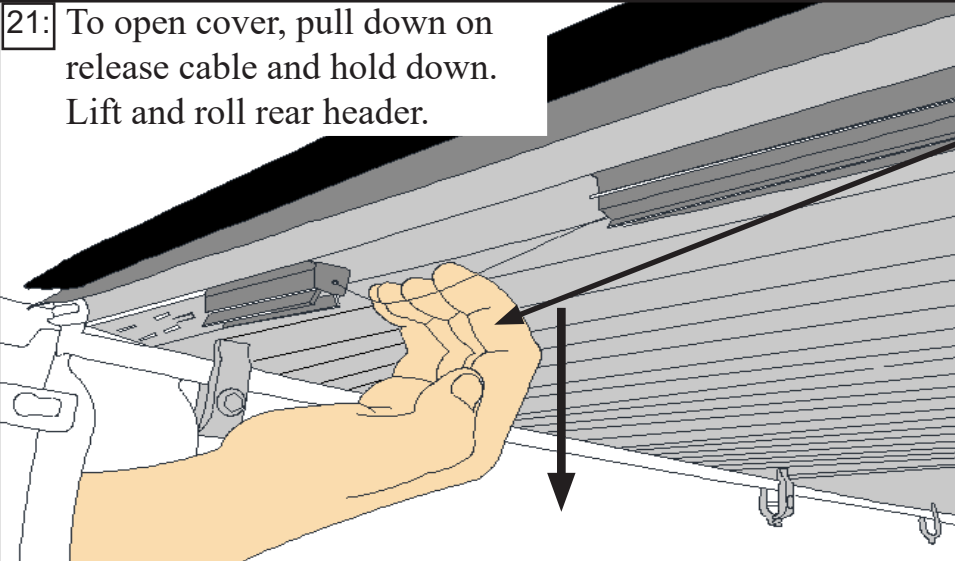

22:

CAUTION

ROLL COVER TIGHT. SECURE THE COVER APPROPRIATELY USING BOTH RETAINER STRAPS. **DO NOT** OVERTIGHTEN. **DO NOT** STOW COVER AGAINST CAB WINDOW.

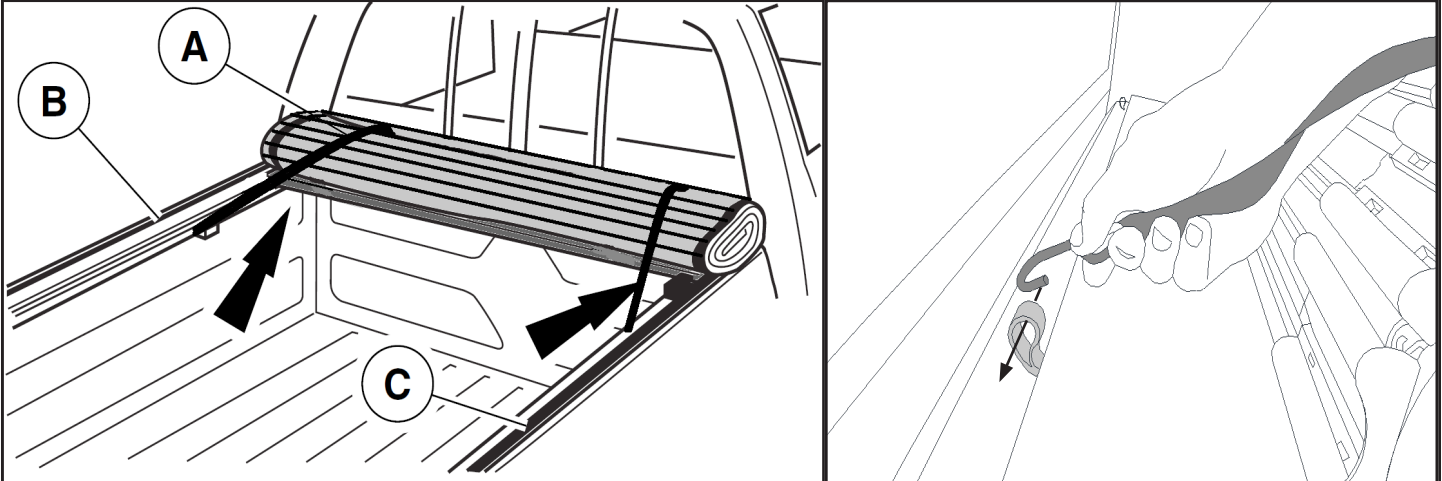

CAUTION

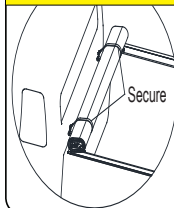

Before driving with cover open, **BOTH STRAPS MUST BE SECURED TO RETAINING LOOPS.** Failure to do so could cause accidental release of the cover, resulting in personal injury or property damage.

23: To Release Strap Push Tab Up.

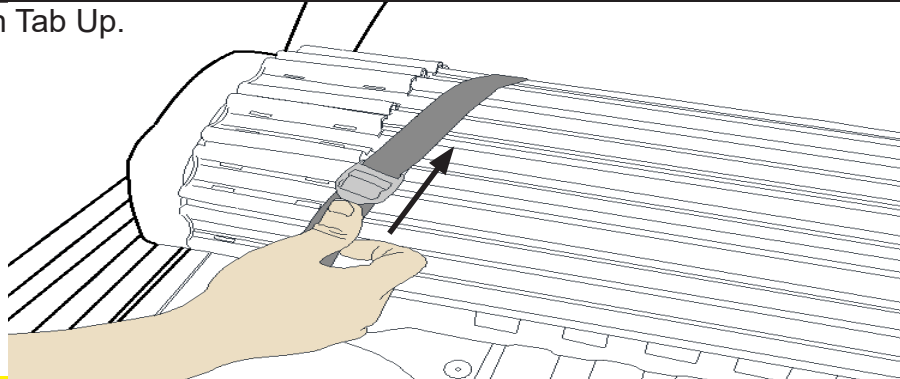

NOTICE: Ice buildup within hinge section can occur if cover is stowed in open position. To prevent potential damage, close cover during winter precipitation.

TROUBLESHOOTING

COVER ASSEMBLY WILL NOT ATTACH TO SIDE RAILS DURING INSTALLATION:

1. Check side rails to make sure they are level.
2. The rolled up cover is heavy which may be flexing the rails downward. Push front of rail up slightly to allow the screw head to fall in the slot and the header guide to slide freely into the secured location (See notes in steps 15,16, and 17).
3. If rear header doesn't latch correctly check side rail installation.

HEADER WILL NOT LATCH:

1. Check side rails to make sure they are level.
2. Make sure the rear header seal is not caught between side rail & rear header.
3. If rear header doesn't latch correctly check side rail installation.
4. Check to make sure side rails are both equally spaced front to rear.
5. Make sure both latches are functioning properly. Clean any debris that may be impeding latches, see COVER CARE AND MAINTENANCE on page 1.
6. Close cover first then tailgate (see alternate closing method in step 19).

COVER IS HARD TO ROLL OPEN OR CLOSED:

1. Truck bed cover **MUST** be free of foreign material including snow and ice before rolling cover.
2. Prolong cold weather will make cover fabric stiff. Move cover into sun or indoors to warm the top surface.
3. It is normal for the cover to experience light binding after being rolled up for an extended period of time. Once the cover is latched, the fabric will relax and the cover will lay flat.

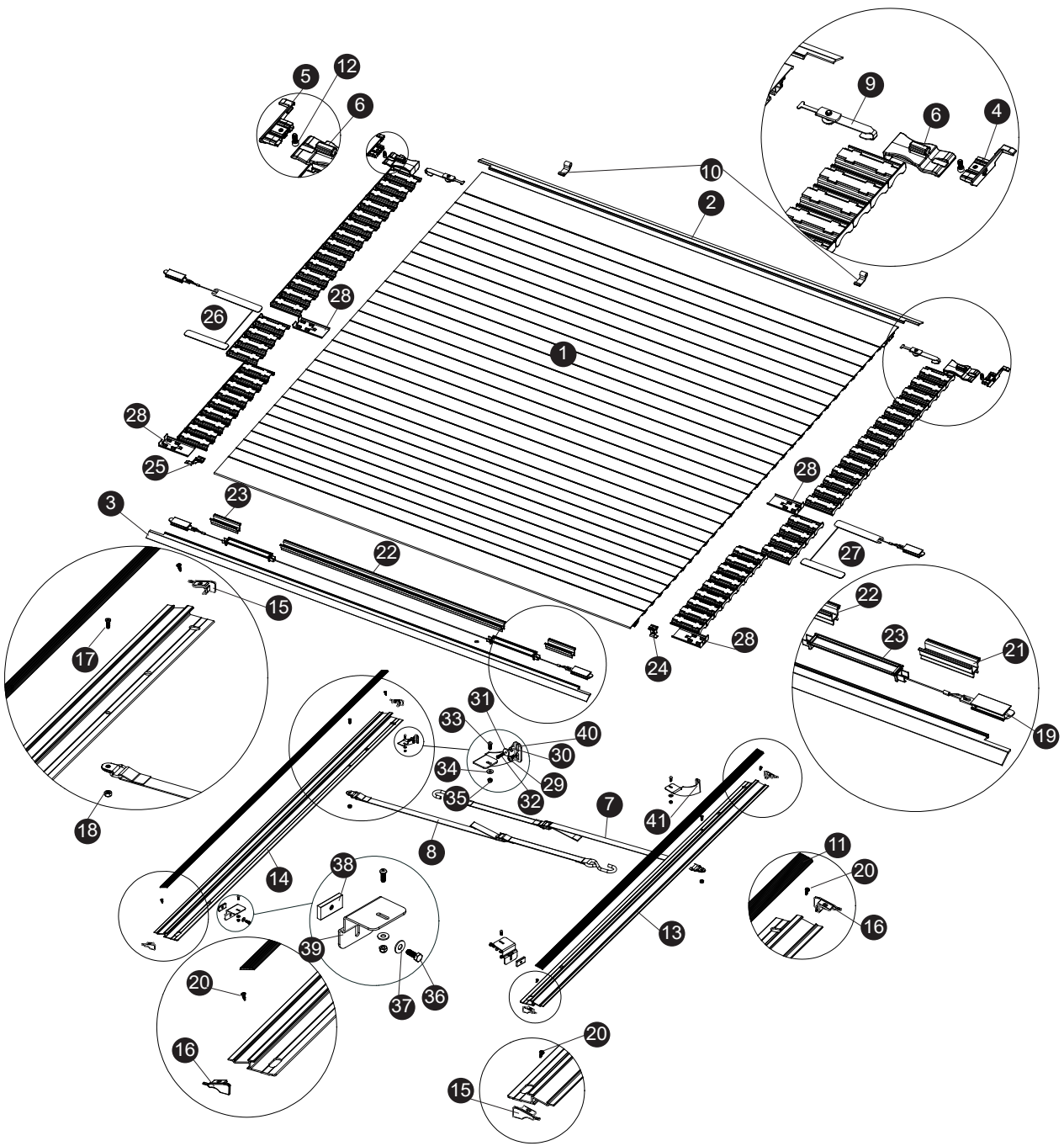

REPLACEMENT PARTS

1	*	Replacement Cover	14	*	Side Rail, Driver's Side	27	*	Passenger Security Latch Assy
2	*	Header Seal, Front	15	1706245	SIDE RAIL ENDPLUG RH	28	1705929	Latch Cover
3	*	Header Seal, Rear	16	1706246	SIDE RAIL END PLUG LH	29	1706277	Cap Screw Button Head M8
4	1705828	Front Header End Plug (Passenger)	17	1705415	Cap Screw 10-24 X 1/2	30	1706279	Well Nut 10-32
5	1705829	Front Header End Plug (Driver)	18	1703762	Hex Nut 10-24	31	1706347	Flat Washer
6	1704707	Header Guide	19	*	Latch System	32	1706278	Cap Screw Button Head 10-32 X 1
7	1117892	Retainer Hook Strap (Passenger)	20	1705629	Self Drill Screw 6-20 X 3/8	33	1705596	Button Head Screw 1/4-20
8	1117893	Retainer Hook Strap (Driver)	21	1118225	Cable Cover 3.75"	34	1700427	Flat Washer 1/4"
9	1117594	Header Guide Retainer	22	*	Cable Cover	35	1701543	Nylon Lock Nut 1/4-20
10	1705806	Extruded Retainer Loop	23	1115822	Cable Guard	36	1705954	Cap Screw Hex Head 5/16-18 X 7/8"
11	*	Hook and Loop Fasteners	24	1705826	Rear Header End Plug (Passenger)	37	1700428	Flat Washer 5/16"
12	1704689	Machine Screw 1/4-20 X 9/16	25	1705825	Rear Header End Plug (Driver)	38	1705880	5/16" Rail System Nut
13	*	Side Rail, Passenger's Side	26	*	Driver Security Latch Assy	39	1706275	Driver/Passenger Rear Bracket
						40	1706273	Driver Front Bracket
						41	1706274	Passenger Front Bracket

* Please specify length or make and model of vehicle.